



A+ Server[®]
AS -2015CS-TNR



USER'S MANUAL

Revision 1.0c

The information in this User's Manual has been carefully reviewed and is believed to be accurate. The vendor assumes no responsibility for any inaccuracies that may be contained in this document, and makes no commitment to update or to keep current the information in this manual, or to notify any person or organization of the updates. Please Note: For the most up-to-date version of this manual, please see our website at www.supermicro.com.

Super Micro Computer, Inc. ("Supermicro") reserves the right to make changes to the product described in this manual at any time and without notice. This product, including software and documentation, is the property of Supermicro and/or its licensors, and is supplied only under a license. Any use or reproduction of this product is not allowed, except as expressly permitted by the terms of said license.

IN NO EVENT WILL Super Micro Computer, Inc. BE LIABLE FOR DIRECT, INDIRECT, SPECIAL, INCIDENTAL, SPECULATIVE OR CONSEQUENTIAL DAMAGES ARISING FROM THE USE OR INABILITY TO USE THIS PRODUCT OR DOCUMENTATION, EVEN IF ADVISED OF THE POSSIBILITY OF SUCH DAMAGES. IN PARTICULAR, SUPER MICRO COMPUTER, INC. SHALL NOT HAVE LIABILITY FOR ANY HARDWARE, SOFTWARE, OR DATA STORED OR USED WITH THE PRODUCT, INCLUDING THE COSTS OF REPAIRING, REPLACING, INTEGRATING, INSTALLING OR RECOVERING SUCH HARDWARE, SOFTWARE, OR DATA.

Any disputes arising between manufacturer and customer shall be governed by the laws of Santa Clara County in the State of California, USA. The State of California, County of Santa Clara shall be the exclusive venue for the resolution of any such disputes. Supermicro's total liability for all claims will not exceed the price paid for the hardware product.

FCC Statement: This equipment has been tested and found to comply with the limits for a Class A or Class B digital device pursuant to Part 15 of the FCC Rules. These limits are designed to provide reasonable protection against harmful interference when the equipment is operated in industrial environment for Class A device or in residential environment for Class B device. This equipment generates, uses, and can radiate radio frequency energy and, if not installed and used in accordance with the manufacturer's instruction manual, may cause harmful interference with radio communications. Operation of this equipment in a residential area is likely to cause harmful interference, in which case you will be required to correct the interference at your own expense.

California Best Management Practices Regulations for Perchlorate Materials: This Perchlorate warning applies only to products containing CR (Manganese Dioxide) Lithium coin cells. "Perchlorate Material-special handling may apply. See www.dtsc.ca.gov/hazardouswaste/perchlorate".



WARNING: This product can expose you to chemicals including lead, known to the State of California to cause cancer and birth defects or other reproductive harm. For more information, go to www.P65Warnings.ca.gov.

The products sold by Supermicro are not intended for and will not be used in life support systems, medical equipment, nuclear facilities or systems, aircraft, aircraft devices, aircraft/emergency communication devices or other critical systems whose failure to perform be reasonably expected to result in significant injury or loss of life or catastrophic property damage. Accordingly, Supermicro disclaims any and all liability, and should buyer use or sell such products for use in such ultra-hazardous applications, it does so entirely at its own risk. Furthermore, buyer agrees to fully indemnify, defend and hold Supermicro harmless for and against any and all claims, demands, actions, litigation, and proceedings of any kind arising out of or related to such ultra-hazardous use or sale.

Manual Revision 1.0c

Release Date: April 11, 2025

Unless you request and receive written permission from Super Micro Computer, Inc., you may not copy any part of this document. Information in this document is subject to change without notice. Other products and companies referred to herein are trademarks or registered trademarks of their respective companies or mark holders.

Copyright © 2025 by Super Micro Computer, Inc.
All rights reserved.

Printed in the United States of America

Preface

About this Manual

This manual is written for professional system integrators and PC technicians. It provides information for the installation and use of the server. Installation and maintenance should be performed by experienced technicians only.

Please refer to the AS -2015CS-TNR server specifications page on our website for updates on supported memory, processors and operating systems (www.supermicro.com).

Notes

For your system to work properly, please follow the links below to download all necessary drivers/utilities and the user's manual for your server.

- Supermicro product manuals: <http://www.supermicro.com/support/manuals/>
- Product drivers and utilities: <https://www.supermicro.com/wdl>
- Product safety info: http://www.supermicro.com/about/policies/safety_information.cfm

If you have any questions, please contact our support team at:
support@supermicro.com

This manual may be periodically updated without notice. Please check the Supermicro website for possible updates to the manual revision level.

Secure Data Deletion

A secure data deletion tool designed to fully erase all data from storage devices can be found on our website: https://www.supermicro.com/about/policies/disclaimer.cfm?url=/wdl/utility/Lot9_Secure_Data_Deletion_Utility/

Warnings

Special attention should be given to the following symbols used in this manual.



Warning! Indicates important information given to prevent equipment/property damage or personal injury.



Warning! Indicates high voltage may be encountered when performing a procedure.

Contents

Contacting Supermicro.....	8
Chapter 1 Introduction	
1.1 Overview.....	9
Network Connection Options	10
1.2 System Features	11
Front View	11
Drive Carrier Indicators.....	11
Control Panel.....	12
Rear View.....	14
Power Supply Indicator.....	15
Top View.....	16
1.3 System Architecture	17
1.4 Motherboard Layout	18
Quick Reference Table.....	19
System Block Diagram.....	20
Chapter 2 Server Installation	
2.1 Overview.....	21
2.2 Unpacking the System	21
2.3 Preparing for Setup	21
Choosing a Setup Location.....	21
Rack Precautions	22
Server Precautions.....	22
Rack Mounting Considerations	22
Ambient Operating Temperature.....	22
Airflow	23
Mechanical Loading.....	23
Circuit Overloading	23
Reliable Ground.....	23
2.4 Installing the Rails	24
Identifying the Rails.....	24
Installing the Outer Rails onto the Rack.....	25
2.5 Installing the Chassis into a Rack.....	26
Removing the Chassis from the Rack	27

Installing the Server into a Telco Rack	28
Chapter 3 Maintenance and Component Installation	
3.1 Removing Power	29
3.2 Accessing the System.....	30
3.3 Processor and Heatsink Installation.....	31
3.4 Memory Support and Installation	39
Memory Support.....	39
DIMM Module Population Sequence	41
DIMM Installation	42
DIMM Removal	42
3.5 Motherboard Battery.....	43
3.6 Storage Drives.....	44
Installing Drives.....	44
3.5" Drive	46
2.5" Drive	47
Installing M.2 Solid State Drives.....	48
3.7 System Cooling	49
Fans	49
Air Shrouds	50
3.8 Power Supply	51
Power Supply LEDs.....	51
3.9 AIOM Cards.....	53
3.10 PCIe Expansion Cards	55
12 SATA only or 12 SATA/4NVME Hybrid	55
12 SATA/12 NVMe Hybrid.....	56
3.11 Cable Routing	59
12x SATA + 4 PCIe x16.....	60
12x SATA + 4 PCIe x16 + Optional 2 PCIe x8.....	61
12x SATA/4x NVMe Hybrid, 4x PCIe x16.....	62
12 NVMe + 2x PCIe x16.....	63
Chapter 4 Motherboard Connections	
4.1 Power Connections	64
4.2 Headers and Connectors	65
4.3 Input/Output Ports	71
4.4 Jumpers.....	72

4.5 LED Indicators.....	73
Chapter 5 Software	
5.1 Microsoft Windows OS Installation.....	75
5.2 Driver Installation.....	77
5.3 SuperDoctor® 5.....	78
5.4 IPMI	79
Chapter 6 Optional Components	
6.1 Storage Control Cards	80
Storage Protocols Supported	80
6.2 Upgrade Fans.....	80
6.3 GPU Support.....	81
6.4 Cable Management Arm.....	81
6.5 TPM Security Module.....	83
Chapter 7 Troubleshooting and Support	
7.1 Information Resources	84
Website	84
Direct Links for the AS-2015CS-TNR System.....	84
Direct Links for General Support and Information	84
7.2 Intelligent Platform Management Interface (IPMI).....	85
7.3 Troubleshooting Procedures	86
Before Power On	86
No Power	86
No Video	86
System Boot Failure.....	87
Memory Errors	87
The System Cannot Retain the Setup Configuration	87
If the System Becomes Unstable.....	87
7.4 Crash Dump Using BMC.....	89
7.5 UEFI BIOS Recovery	90
Overview	90
Recovering the UEFI BIOS Image.....	90
Recovering the Main BIOS Block with a USB Device.....	90
7.6 CMOS Clear	95
7.7 Where to Get Replacement Components.....	96
7.8 Reporting an Issue	96

Technical Support Procedures96

Returning Merchandise for Service.....96

Vendor Support Filing System97

7.9 Feedback.....97

Appendix A Standardized Warning Statements for AC Systems

Appendix B System Specifications

Contacting Supermicro

Headquarters

Address: Super Micro Computer, Inc.
980 Rock Ave.
San Jose, CA 95131 U.S.A.

Tel: +1 (408) 503-8000

Fax: +1 (408) 503-8008

Email: marketing@supermicro.com (General Information)
Sales-USA@supermicro.com (Sales Inquiries)
Government_Sales-USA@supermicro.com (Gov. Sales Inquiries)
support@supermicro.com (Technical Support)
RMA@supermicro.com (RMA Support)
Webmaster@supermicro.com (Webmaster)

Website: www.supermicro.com

Europe

Address: Super Micro Computer B.V.
Het Sterrenbeeld 28, 5215 ML
's-Hertogenbosch, The Netherlands

Tel: +31 (0) 73-6400390

Fax: +31 (0) 73-6416525

Email: Sales_Europe@supermicro.com (Sales Inquiries)
Support_Europe@supermicro.com (Technical Support)
RMA_Europe@supermicro.com (RMA Support)

Website: www.supermicro.nl

Asia-Pacific

Address: Super Micro Computer, Inc.
3F, No. 150, Jian 1st Rd.
Zhonghe Dist., New Taipei City 235
Taiwan (R.O.C)

Tel: +886-(2) 8226-3990

Fax: +886-(2) 8226-3992

Email: Sales-Asia@supermicro.com.tw (Sales Inquiries)
Support@supermicro.com.tw (Technical Support)
RMA@supermicro.com.tw (RMA Support)

Website: www.supermicro.com.tw

Chapter 1

Introduction

1.1 Overview

This chapter provides an outline of the functions and features of the SuperServer AS -2015CS-TNR. The following provides an overview of the specifications and capabilities.

System Overview	
Motherboard	H13SSW
Chassis	CSE-LA26TS-R1K23AWP1
Processors	Single AMD EPYC™ 9004/9005 (Motherboard revision 2.0 or later is required) Series processor in SP5 socket and a Thermal Design Power (TDP) unit up to 400 W* (*Depending on thermal validation and system configuration. Contact a Supermicro representative for details.)
Memory	12 DIMM slots with 1DPC that support <ul style="list-style-type: none"> • 3 TB of ECC DDR5/3DS RDIMM at 4800 MT/s (AMD EPYC™ 9004 Series Processors) • 3 TB of ECC DDR5/3DS RDIMM at 6000 MT/s (Requires AMD EPYC™ 9005 Series Processors and motherboard revision 2.00 or later) • 3 TB of ECC DDR5/3DS RDIMM at 6400 MT/s (Requires AMD EPYC™ 9005 Series Processors and motherboard revision 2.01 or later) See Section 3.4 for details
Storage	12 3.5"/2.5" hot-swap hybrid SATA/NVMe*/SAS* drive bays (*requires additional parts) Two Gen 3 M.2 NVMe PCIe 3.0 x2 SSDs for boot drive
Expansion Slots	Two PCIe 5.0 x16 FHFL* Two PCIe 5.0 x16 FHHL Two PCIe 5.0 x8 FHFL (Optional)** *With 12 NVMe, only one FHFL is available. **PCIe Slots 2 and 4 are not available with NVMe drive option
I/O Ports	Two AIOM network modules, PCIe 5.0 x16 (OCP 3.0 NIC) One dedicated LAN port Two USB 3.0 ports (rear) One VGA port (rear) One serial port (rear)
System Cooling	Three counter-rotating fans with optimal fan speed control One air shroud
Power	Two 1200 W redundant power supplies, 80Plus Titanium level* (*Full redundancy based on configuration and application load)
Form Factor	2U: 17.2" x 3.5" x 25.5" (depth) (43.7 x 8.9 x 64.8 cm)

A Quick Reference Guide can be found on the [product page](#) of the Supermicro website.

The following safety models associated with the AS -2015CS-TNR have been certified as compliant with UL or CSA: LA26CDC-R8H13, LA26CDC-R12H13, LA26-R16H13, LA26CDC-R11DH13, LA26-8, LA26-12, LA26-16, LA26-11D.

Network Connection Options

The system accepts many different advanced input/output module (AIOMs) that provide network connectivity. It supports OCP 3.0 specifications using PCIe Gen 5.0 x16. Options include RJ45, SFP+, QSFP28, etc. at 1/10/25/100GbE capabilities, with two or four ports per module, up to two modules. See the web [product page](#) for current choices. At [supermicro.com](#), search for the product by model number.

1.2 System Features

The following views of the system display the main features. Refer to [Appendix B](#) for additional specifications.

Front View



Figure 1-1. Front View

Logical Storage Drive Numbers	
Item	Description
0 - 11	12 x3.5/2.5-inch front drive bays (NVMe*/SAS*/SATA)

* NVMe or SAS support available with additional parts; See cable routing section.

Drive Carrier Indicators

Each drive carrier has two LED indicators: an activity indicator and a status indicator. For RAID configurations using a controller, the meaning of the status indicator is described in the table below. For OS RAID or non-RAID configurations, some LED indications are not supported, such as hot spare.

Drive Carrier LED Indicators			
	Color	Blinking Pattern	Behavior for Device
Activity LED	Blue	Solid On	Idle SAS/NVMe drive installed
	Blue	Blinking	I/O activity
	Off		Idle SATA or no drive installed
Status LED	Red	Solid On	Drive failure
	Red	Blinking at 1 Hz	Rebuilding drive
	Red	Blinking with two blinks and one stop at 1 Hz	Hot spare for drive
	Red	On for five seconds, then off	Power on for drive
	Red	Blinking at 4 Hz	Identifying drive
	Green	Solid on	Safe to remove NVMe drive
	Off		Idle SATA or no drive installed

Control Panel

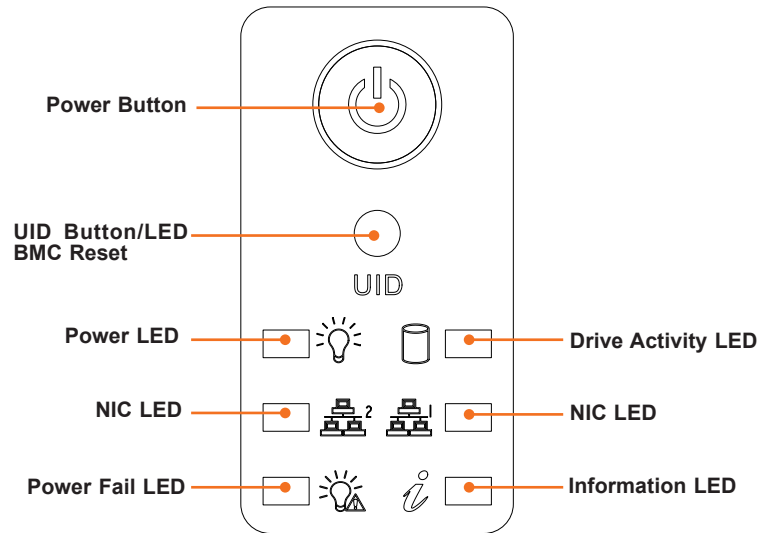

Figure 1-2. Control Panel

Control Panel Features	
Feature	Description
Power Button	The main power switch applies or removes primary power from the power supply to the server but maintains standby power.
UID Button/LED BMC Button	The unit identification (UID) button turns on or off the blue light function of the Information LED and a blue LED on the rear of the chassis. This button can also be used to reset the BMC and will disable the rear VGA port to enable the front VGA port, if available.
Power LED	Steady on – Power on Blinking at 4 Hz – Checking BIOS/BMC integrity Blinking at 4 Hz and "i" LED is blue – BIOS firmware updating Two blinks at 4 Hz, one pause 2 Hz and "i" LED blue – BMC firmware updating Blinking at 1 Hz and "i" LED red – Fault detected
NIC LEDs	Indicates network activity on LANs when flashing; defaults to the first two ports of the CPU1 AIOM
Power Fail LED	Indicates a power supply module has failed.
Drive Activity LED	Indicates activity on the hard drive when flashing.
Information LED	Alerts operator to several states, as noted in the table below.

Information LED	
Color, Status	Description
Red, solid	An overheat condition has occurred.
Red, blinking at 1 Hz	Fan failure, check for an inoperative fan.
Red, blinking at 0.25 Hz	Power failure, check for a non-operational power supply.
Red, solid, with Power LED blinking green	Fault detected
Blue and red, blinking at 10 Hz	Recovery mode
Blue, solid	UID has been activated locally to locate the server in a rack environment.
Blue, blinking at 1 Hz	UID has been activated using the BMC to locate the server in a rack environment.
Blue, blinking at 2 Hz	BMC is resetting
Blue, blinking at 4 Hz	BMC is setting factory defaults
Blue, blinking at 10 Hz with Power LED blinking green	BMC/BIOS firmware is updating

Rear View

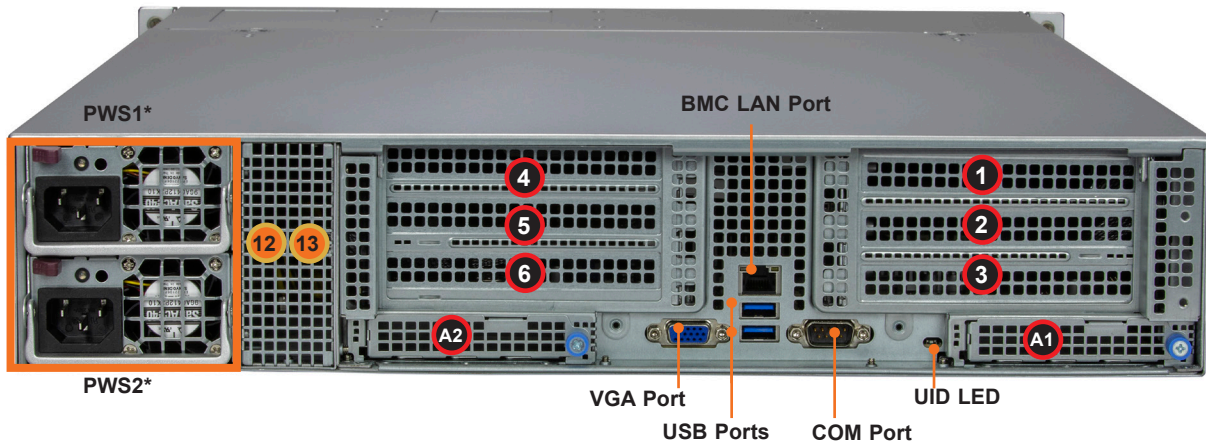

Figure 1-3. System: Rear View

System Features: Rear	
Feature	Description
Power Supplies	Two redundant power supply modules**
VGA Port	One VGA port
USB Ports	Two USB 3.0 ports
COM Port	Serial port
UID LED	Unit identifier indicator light
Dedicated BMC LAN Port	BMC LAN port; for indicator details, see BMC LAN LEDs

*** Full redundancy based on configuration and application load.

Optional Logical Storage Drive Numbers	
Item	Description
12 - 13	Optional 2.5" hot-swap NVMe/SAS/SATA drive bays***

*** Requires additional parts in optional parts list; Depending on drive option, using rear drive bay may limit front drive and/or PCIe slot options. Contact support for details.

Expansion Card Slots	
Item	Description
1	PCIe 5.0 x16 slot (FHFL)
2	PCIe 5.0 x8 slot (FHFL) (optional)*
3	PCIe 5.0 x16 slot (FHHL)
4	PCIe 5.0 x8 slot (FHFL) (optional)*
5	PCIe 5.0 x16 slot (FHFL)
6	PCIe 5.0 x16 slot (FHHL)
A1	PCIe 5.0 x16 OCP 3.0 Compatible AIOM slot
A2	PCIe 5.0 x16 OCP 3.0 Compatible AIOM slot

* PCIe slots 2 and 4 are not available with NVMe drive option.

Power Supply Indicator

Power Supply Indicator	
LED Color and State	Power Supply Condition
Solid Green	Indicates that the power supply is on
Blinking Green	Indicates that the power supply is plugged in and turned off by the system.
Blinking Amber	Indicates that the power supply has a warning condition and continues to operate.
Solid Amber	Indicates that the power supply is plugged in, and is in an abnormal state. The system might need service. Please contact Supermicro technical support.
Off	No AC power to modules

Top View

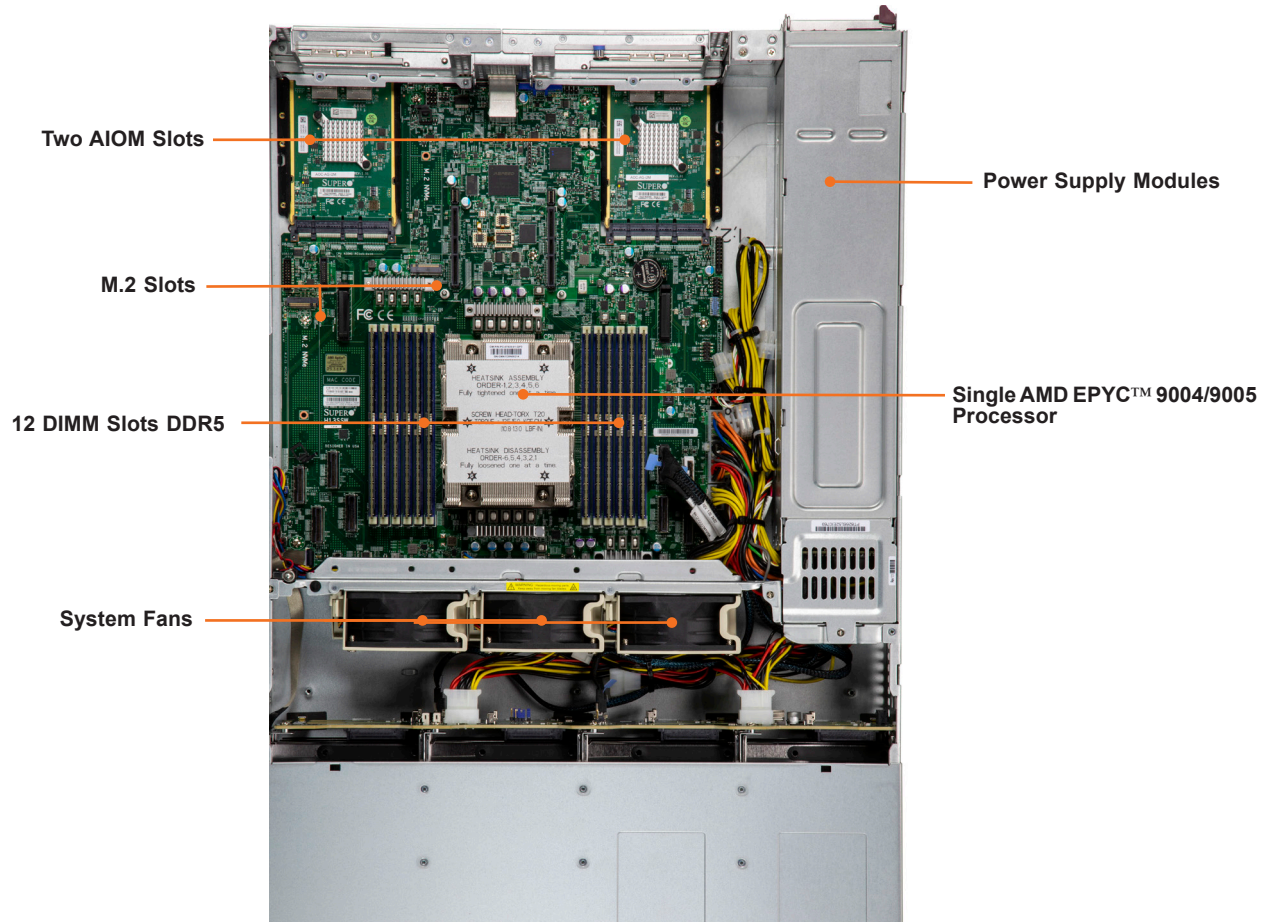

Figure 1-4. System: Top View

System Features: Top	
Feature	Description
AIOM Slots	Two Advanced I/O modules
M.2 Slots	Two M.2 NVMe Gen3 slots (for boot)
Power Supply	Dual redundant modules
DIMM Slots	12 DIMM DDR5 slots
Processors	Single AMD EPYC™ 9004/9005 (Motherboard revision 2.0 or later is required) Series processor
System Fans	Three 4-cm counter-rotating fans with optimal fan speed control, FAN-0206L4

1.3 System Architecture

This section shows the locations of the system's main components.

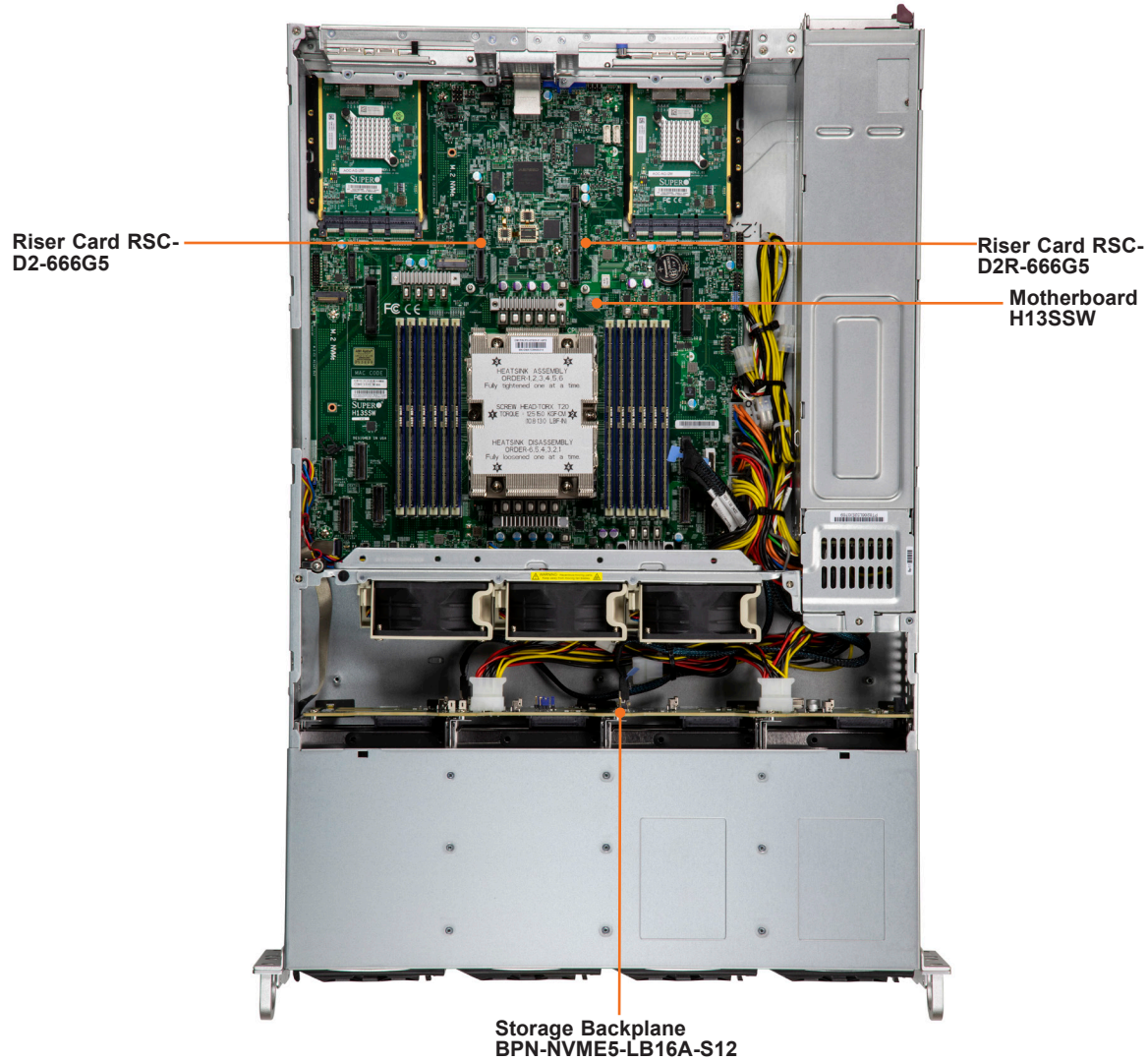

Figure 1-5. Main Component Locations

1.4 Motherboard Layout

Below is a layout of the H13SSW motherboard with jumper, connector and LED locations shown. See the table on the following page for descriptions. For detailed descriptions, pinout information and jumper settings, refer to [Chapter 4](#) or the [Motherboard Manual](#).

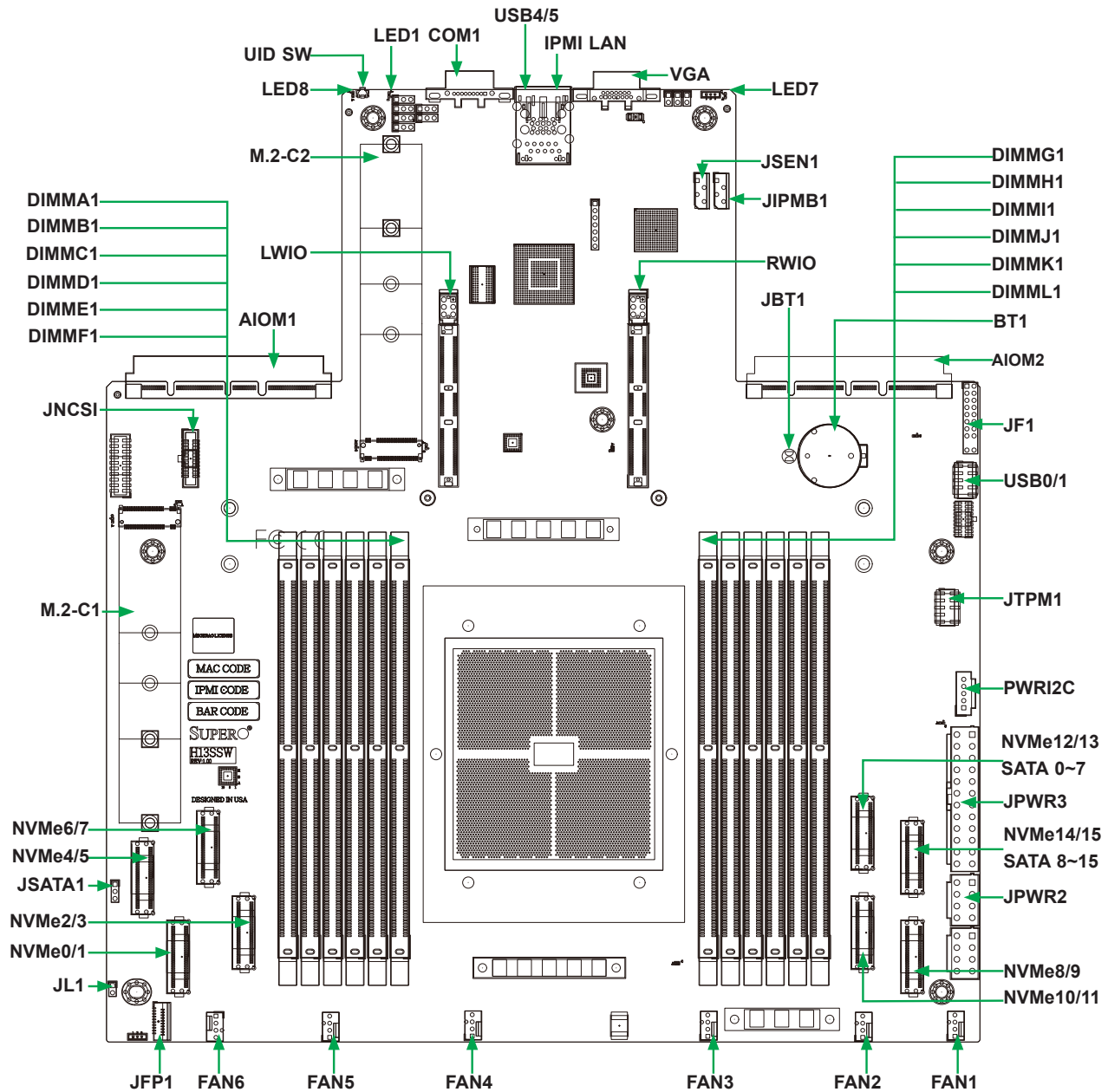

Figure 1-6. Motherboard Layout

Quick Reference Table

Jumper	Description	Default Setting
JBT1	CMOS Clear	Open (Normal)
UID SW	Unit ID Switch (Push-Button Toggle Switch ON/OFF)	Off

LED	Description	Status
LED7	Power LED	Solid Green: Power On
LED1	BMC Heartbeat LED	Green: Blinking (BMC Normal) Green: Fast Blinking (BMC Initializing)
LED8	UID LED	Blue: UID Activated

Connector	Description
JL1	Chassis Intrusion Header
JSATA1	3-Pin Connector for HDD Use
JNCSI1	NCSI Connector
JPWR2	12V 8-Pin CPU Core Power Supply Connector
JPWR3	24-Pin ATX Power Supply Connector
JF1	Front Control Panel Header
BT1	Onboard Battery
M.2-C1/M.2-C2	M.2 PCIe Interfaces
NVMe0~11	NVMe Ports
NVMe12~15, SATA0~15	NVMe/SATA Hybrid Ports
JIPMB1	4-Pin BMC External I ² C Header (For an IPMI-Supported Card)
DIMMA1~DIMML1	DIMM Slots
FAN1~FAN6	System Cooling Fans
AIOM1~AIOM2	Supermicro® Advanced I/O Module (AIOM) Slots
JFP1	Front Control Panel Header 1
LWIO/ RWIO	Riser Slots
IPMI LAN	RJ45 Dedicated IPMI LAN Port
JTPM1	TPM (Trusted Platform Module)/Port 80
PWRI2C	Power Supply SMBus I2C Header
COM1	Rear Panel COM Port #1
VGA	Rear Panel VGA Port
JSEN1	Inlet Sensor Header
USB0/1	USB 2.0 Ports
USB4/5	USB 3.0 Ports

Note: Jumpers, connectors, switches, and LED indicators that are not described in the preceding tables are for manufacturing testing purposes only, and are not covered in this manual.

System Block Diagram

H13SSW
AMD SP5 Rev. 1.01

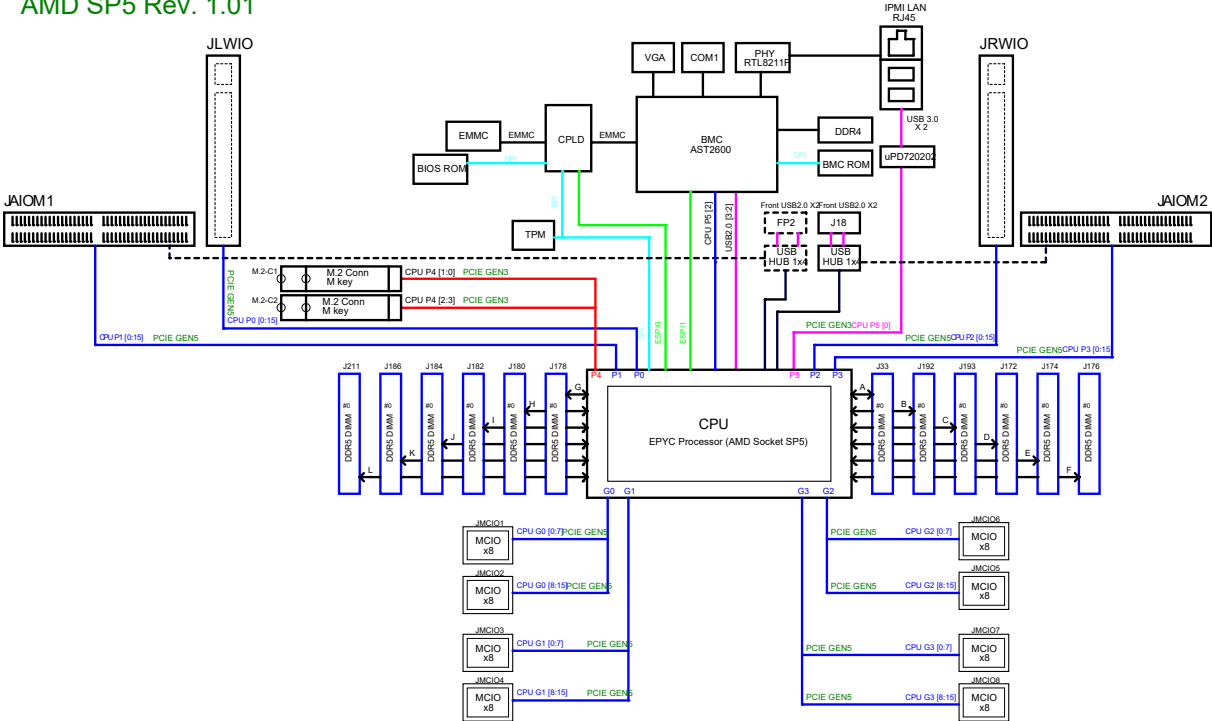

Figure 1-7. Chipset Block Diagram

Note: This is a general block diagram and may not exactly represent the features in your system.

Chapter 2

Server Installation

2.1 Overview

This chapter provides advice and instructions for mounting your system in a server rack. If your system is not already fully integrated with processors, system memory etc., refer to [Chapter 3](#) for details on installing those specific components.

Important: Electrostatic Discharge (ESD) can damage electronic components. To prevent such damage to PCBs (printed circuit boards), it is important to use a grounded wrist strap, handle all PCBs by their edges and keep them in anti-static bags when not in use.

2.2 Unpacking the System

Inspect the box in which the system was shipped, and note if it was damaged. If any equipment appears damaged, file a claim with the carrier.

Decide on a suitable location for the rack unit that will hold the server. It should be situated in a clean, dust-free area that is well ventilated. Avoid areas where heat, electrical noise and electromagnetic fields are generated. It will also require a grounded AC power outlet nearby. Be sure to read the precautions and considerations noted in [Appendix A](#).

2.3 Preparing for Setup

The box in which the system was shipped should include the rackmount hardware needed to install it into the rack. Please read this section in its entirety before you begin the installation.

Choosing a Setup Location

- The system should be situated in a clean, dust-free area that is well ventilated. Avoid areas where heat, electrical noise and electromagnetic fields are generated.
- Leave enough clearance in front of the rack so that you can open the front door completely (~25 inches) and approximately 30 inches of clearance in the back of the rack to allow sufficient space for airflow and access when servicing.
- This product should be installed only in a Restricted Access Location (dedicated equipment rooms, service closets, etc.).

- This product is not suitable for use with visual display workplace devices according to §2 of the German Ordinance for Work with Visual Display Units.

Rack Precautions

- Ensure that the leveling jacks on the bottom of the rack are extended to the floor so that the full weight of the rack rests on them.
- In single rack installations, stabilizers should be attached to the rack. In multiple rack installations, the racks should be coupled together.
- Always make sure the rack is stable before extending a server or other component from the rack.
- You should extend only one server or component at a time - extending two or more simultaneously may cause the rack to become unstable.

Server Precautions

- Review the electrical and general safety precautions in [Appendix A](#).
- Determine the placement of each component in the rack *before* you install the rails.
- Install the heaviest server components at the bottom of the rack first and then work your way up.
- Use a regulating uninterruptible power supply (UPS) to protect the server from power surges and voltage spikes and to keep your system operating in case of a power failure.
- Allow any drives and power supply modules to cool before touching them.
- When not servicing, always keep the front door of the rack and all covers/panels on the servers closed to maintain proper cooling.

Rack Mounting Considerations

Ambient Operating Temperature

If installed in a closed or multi-unit rack assembly, the ambient operating temperature of the rack environment may be greater than the room's ambient temperature. Therefore, consideration should be given to installing the equipment in an environment compatible with the manufacturer's maximum rated ambient temperature (TMRA).

Airflow

Equipment should be mounted into a rack so that the amount of airflow required for safe operation is not compromised.

Mechanical Loading

Equipment should be mounted into a rack so that a hazardous condition does not arise due to uneven mechanical loading.

Circuit Overloading

Consideration should be given to the connection of the equipment to the power supply circuitry and the effect that any possible overloading of circuits might have on overcurrent protection and power supply wiring. Appropriate consideration of equipment nameplate ratings should be used when addressing this concern.

Reliable Ground

A reliable ground must be maintained at all times. To ensure this, the rack itself should be grounded. Particular attention should be given to power supply connections other than the direct connections to the branch circuit (i.e. the use of power strips, etc.).

Important: To prevent bodily injury when mounting or servicing this unit in a rack, you must take special precautions to ensure that the system remains stable. The following guidelines are provided to ensure your safety:

- This unit should be mounted at the bottom of the rack if it is the only unit in the rack.
- When mounting this unit in a partially filled rack, load the rack from the bottom to the top with the heaviest component at the bottom of the rack.
- If the rack is provided with stabilizing devices, install the stabilizers before mounting or servicing the unit in the rack.
- Slide rail mounted equipment is not to be used as a shelf or a work space.

2.4 Installing the Rails

There are a variety of rack units on the market, which may require a slightly different assembly procedure. This rail set fits a rack between 25.6" and 33" deep.

The following is a basic guideline for installing the system into a rack with the rack mounting hardware provided. You should also refer to the installation instructions that came with the specific rack you are using.

If you are installing into a two-post "telco" rack, skip to that section later in this chapter.

Identifying the Rails

The chassis comes with two sets of rack rail (MCP-290-00053-0N), one set for the right side of the chassis and one for the left. Each set consists of an inner rail that is pre-attached to the chassis, an outer rail that attaches to the rack, and a middle rail that slides forward in the outer rail.

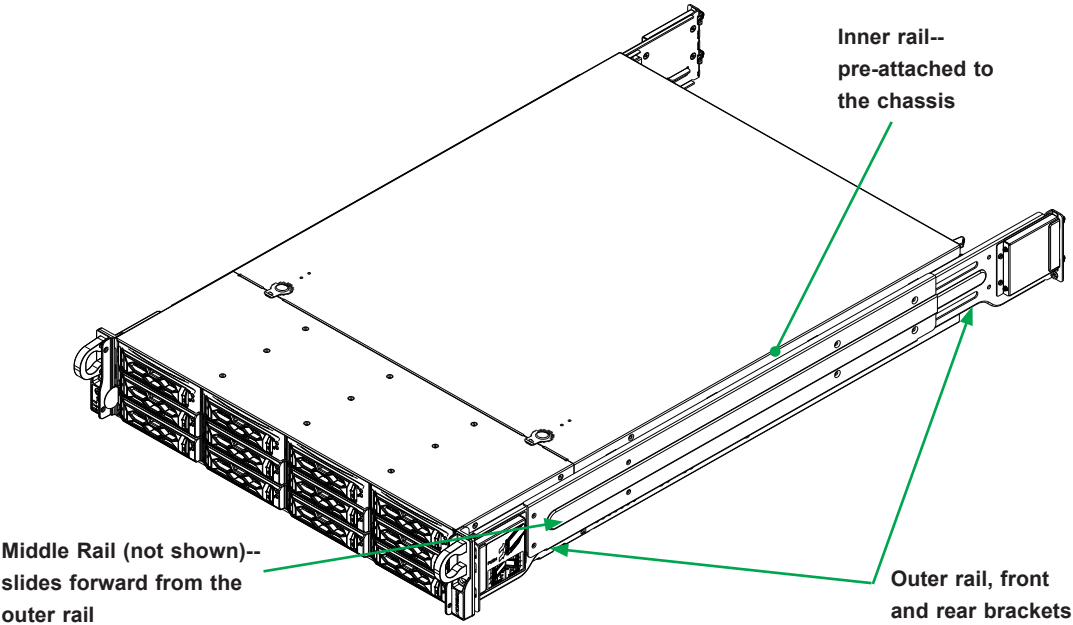

Figure 2-1. Identifying the Sections of the Rack Rails

Installing the Outer Rails onto the Rack

Each end of the assembled outer rail includes a bracket with square pegs to fit into your rack holes. If you have an older rack with round holes, these brackets must be removed, and you must use screws to secure the rail to the rack.

Outer Rail Installation

1. Align the square pegs on the front end of the rail with the square holes on the front of the rack (C). Push the rail into the rack until the quick release bracket snaps into place, securing the rail to the rack. Keep the rail horizontal.
2. Adjust the rail to reach just past the full depth of your rack.
3. Align the square pegs on the rear end of the rail to the holes on the rack (D) and push the rail into the rack until the quick release bracket snaps into place, securing the rail to the rack.

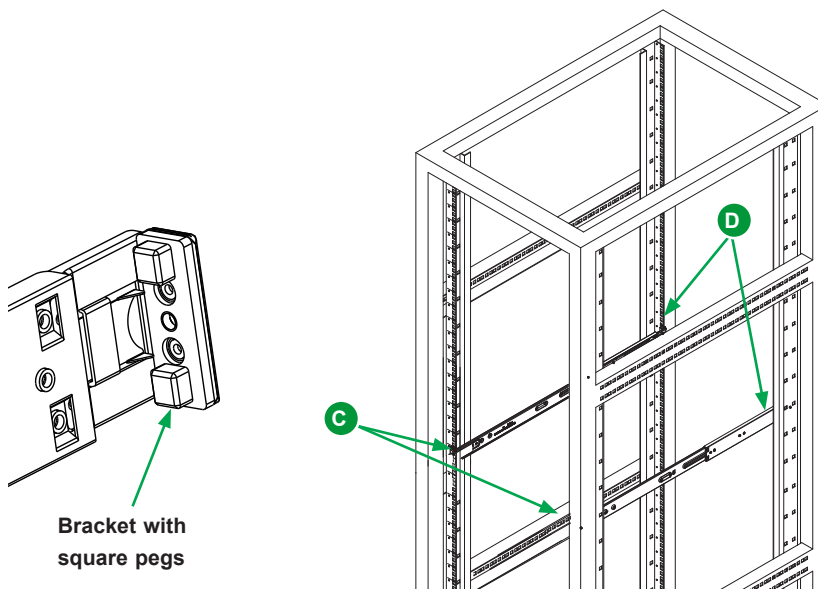

Figure 2-2. Installing the Outer Rails to the Rack

Note: The figure above is for illustrative purposes only. Always install servers at the bottom of the rack first.

Stability hazard. The rack stabilizing mechanism must be in place, or the rack must be bolted to the floor before you slide the unit out for servicing. Failure to stabilize the rack can cause the rack to tip over.

2.5 Installing the Chassis into a Rack

Once rails are attached to the chassis and the rack, you can install the server.

1. Pull the middle rail out of the front of the outer rail and make sure that the ball bearing shuttle is locked at the front of the middle rail.
2. Align the rear of the chassis rails with the middle rails and then push evenly on both sides of the chassis until it clicks into the fully extended position.
3. Depress the locking tabs on both sides of the chassis and push the it fully into the rack. The locking tabs should "click".
4. Thumb screws may be used to secure the front of the chassis to the rack.

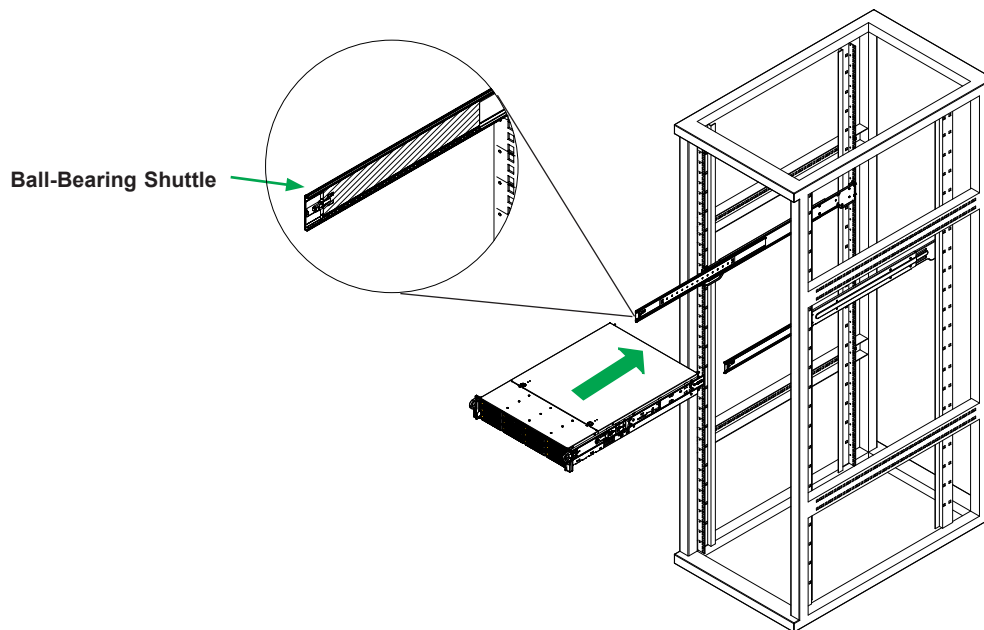

Figure 2-3. Installing the Server into the Rack

Notes: Keep the ball bearing shuttle locked at the front of the middle rail during installation. Figure is for illustrative purposes only. Always install servers to the bottom of a rack first.

Removing the Chassis from the Rack

Important: It is dangerous for a single person to off-load the heavy chassis from the rack without assistance. Be sure to have sufficient assistance supporting the chassis when removing it from the rack. Use a lift.

1. If necessary, loosen the thumb screws on the front of the chassis that hold it in the rack.
2. Pull the chassis forward out the front of the rack until it stops.
3. Press the release latches on each of the inner rails downward simultaneously and continue to pull the chassis forward and out of the rack.

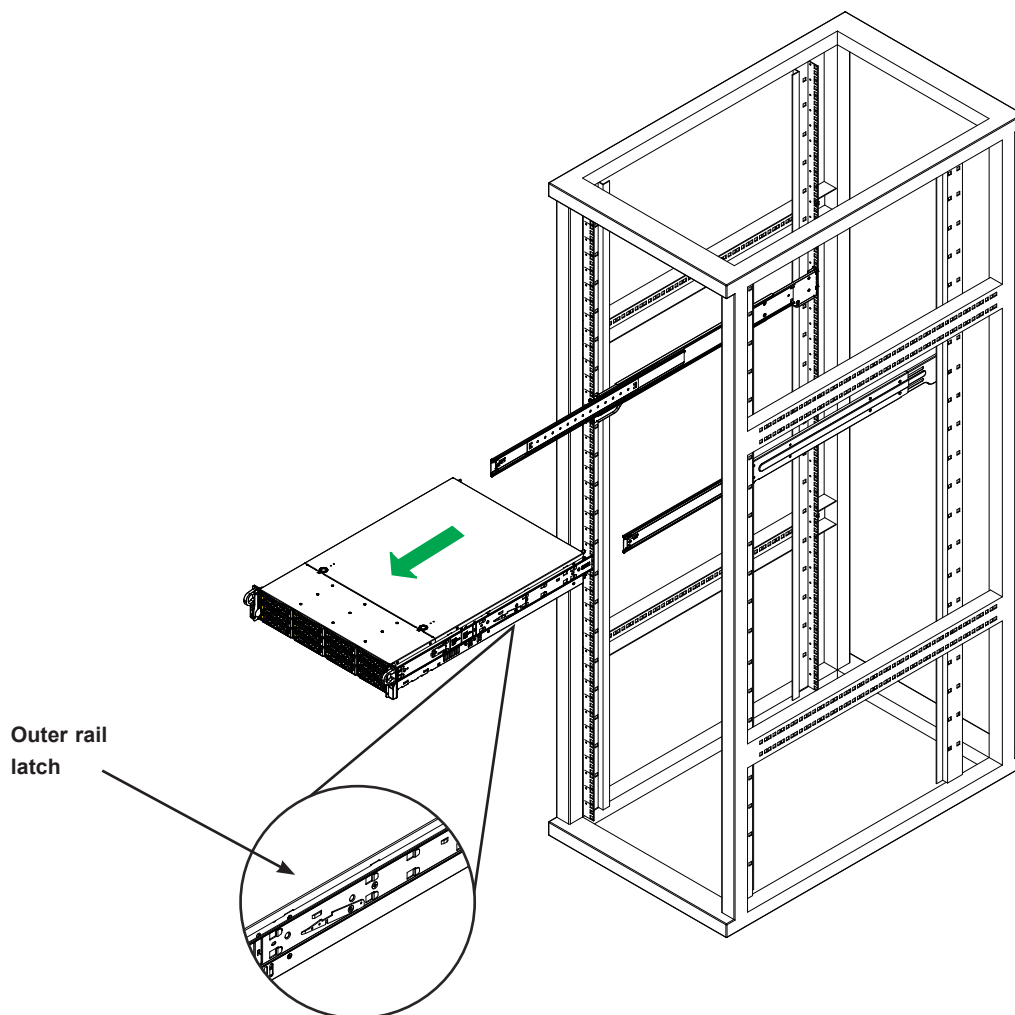

Figure 2-4. Removing the Chassis From the Rack

Installing the Server into a Telco Rack

To install the server into a Telco (or “open”) type rack, use L-shaped brackets (p/n MCP-290-00016-0N) on either side of the chassis (four total).

1. Determine how far the server will extend out from the front of the rack. The chassis should be positioned so that the weight is balanced between front and back.
2. Attach the two front brackets to each side of the chassis, then the two rear brackets positioned with just enough space to accommodate the width of the rack.
3. Finish by sliding the chassis into the rack and tightening the brackets to the rack.

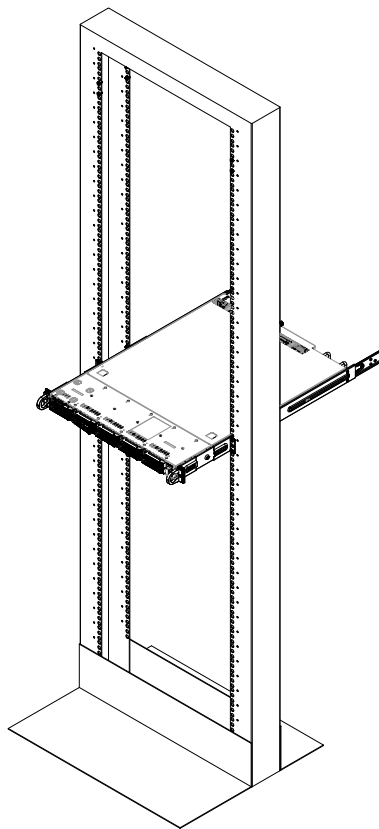

Figure 2-5. Installing the Server into a Telco Rack

Note: The figure above is for illustrative purposes only. Always install servers at the bottom of the rack first.

Chapter 3

Maintenance and Component Installation

This chapter provides instructions on installing and replacing main system components. To prevent compatibility issues, only use components that match the specifications and/or part numbers given.

Installation or replacement of most components require that power first be removed from the system. Please follow the procedures given in each section.

3.1 Removing Power

Use the following procedure to ensure that power has been removed from the system. This step is necessary when removing or installing non hot-swap components or when replacing a non-redundant power supply.

1. Use the operating system to power down the system.
2. After the system has completely shut-down, disconnect the AC power cord(s) from the power strip or outlet. (If your system has more than one power supply, remove the AC power cords from all power supply modules.)
3. Disconnect the power cord(s) from the power supply module(s).

Note: This removing power procedure applies when changing any component or subsystem that is not hot-swap/hot-plug.

3.2 Accessing the System

The chassis features a removable top cover for access to the internal components.

Removing the Top Cover

1. Unscrew the thumbscrew at the rear of the cover and slide the cover toward the rear.
2. Lift the top cover up.

Check that all ventilation openings on the top cover and the top of the chassis are clear and unobstructed.

Important: Except for short periods of time, do not operate the server without the cover in place. The chassis cover must be in place to allow for proper airflow and to prevent overheating.

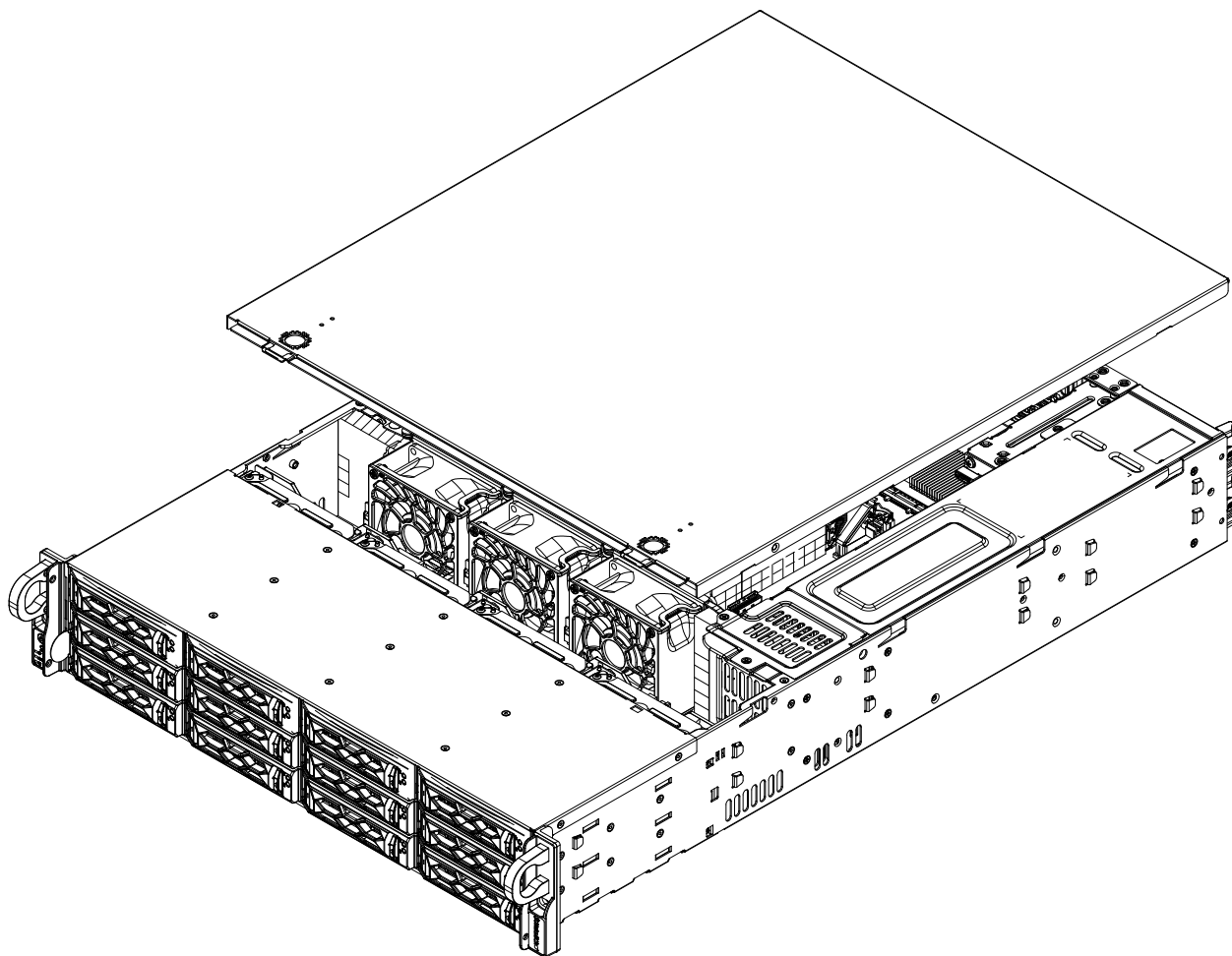

Figure 3-1. Removing the Chassis Cover

3.3 Processor and Heatsink Installation

Important: When handling the processor package, avoid placing direct pressure on the label area of the fan.

Important:

- For the Processor/Heatsink installation you need to use a T20 screwdriver when opening/closing the CPU socket.
- Always connect the power cord last, and always remove it before adding, removing or changing any hardware components. Make sure that you install the processor into the CPU socket before you install the CPU heatsink.
- If you buy a CPU separately, make sure that you use an AMD-certified multi-directional heatsink only.
- Make sure to install the motherboard into the chassis before you install the CPU heatsink.
- When receiving a motherboard without a processor pre-installed, make sure that the plastic CPU socket cap is in place and none of the socket pins are bent; otherwise, contact your retailer immediately.
- Refer to the Supermicro website for updates on CPU support.

Installing the Processor and Heatsink

1. Unscrew the screw #1 holding down the force frame.

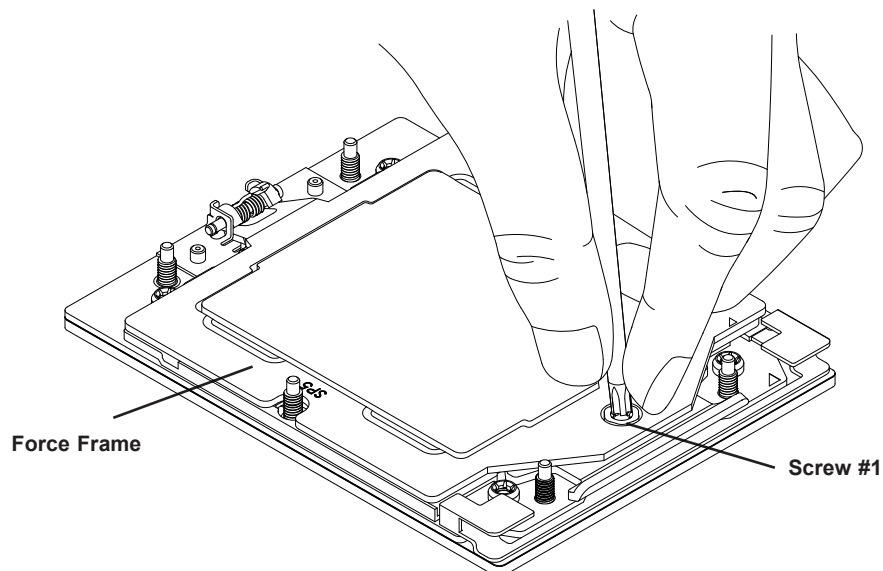

2. The spring-loaded force frame will raise up after the screw securing it (#1) is removed. Gently allow it to lift up to its stopping position.

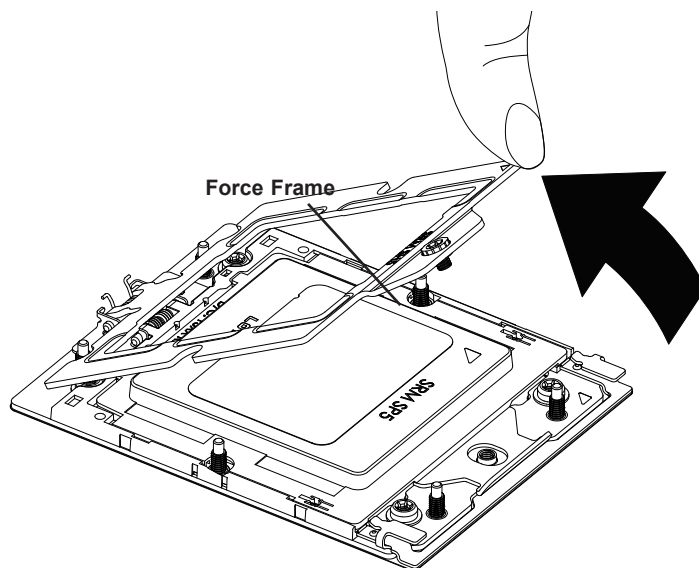

3. Lift the rail frame up by gripping the lift tabs near the front end of the rail frame. While keeping a secure grip of the rail frame, lift it to a position so you can do the next step of removing the external cap. Remove the external cap from the rail frame by pulling it upwards through the rail guides on the rail frame.

Note: The rail frame is spring loaded, so keep a secure grip on it as you lift it so it does not snap up.

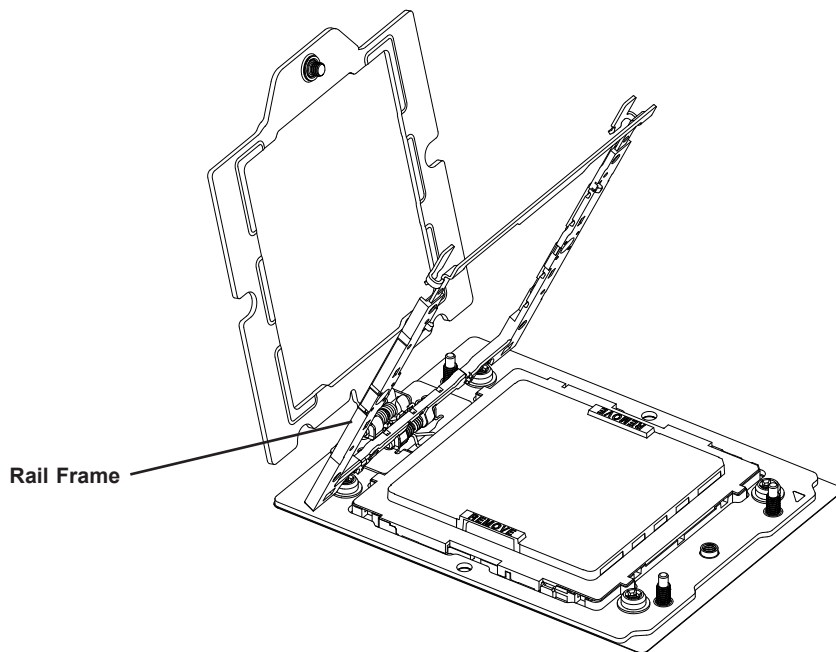

4. Remove the external cap from the rail frame by pulling it upwards through the rail guides on the rail frame.

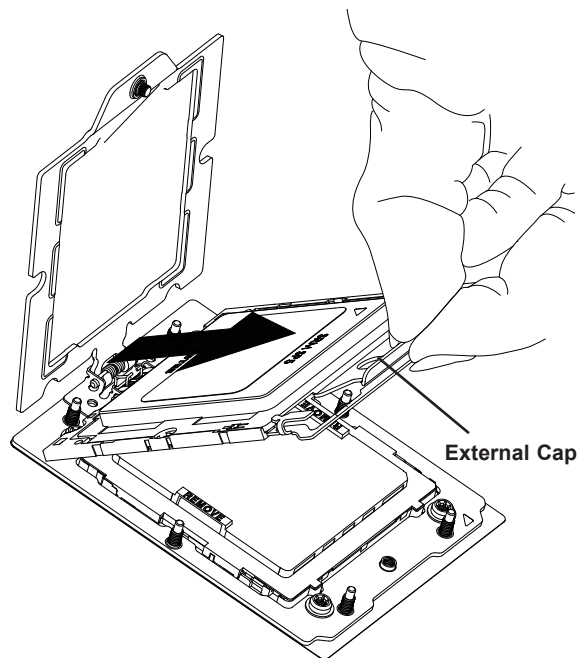

5. The CPU package is shipped from the factory with the carrier frame pre-assembled. Grip the handle of the carrier frame/CPU package assembly from its shipping tray, and while gripping the handle, align the flanges of the carrier frame onto the rails of the rail frame so its pins will be at the bottom when the rail frame is lowered later.
6. Slide the carrier frame/CPU package downwards to the bottom of the rail frame. Ensure the flanges are secure on the rails as you lower it downwards.

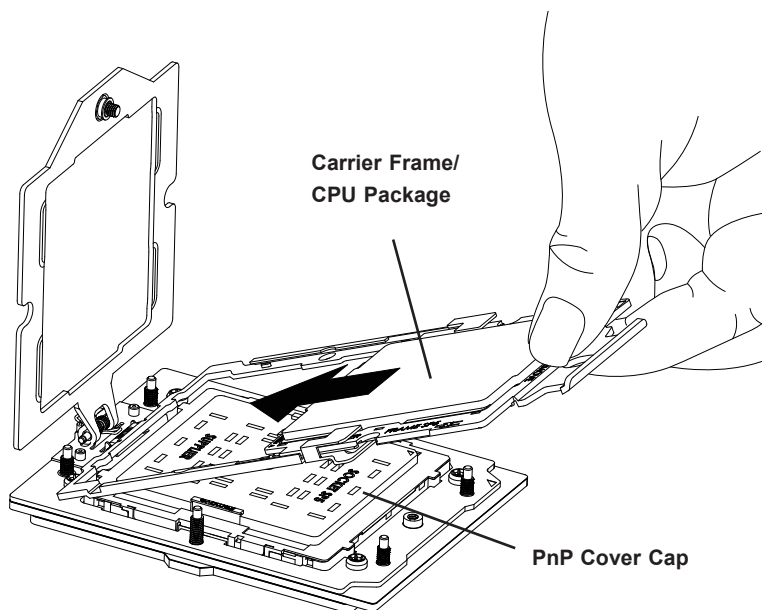

Note: You can only install the CPU inside the socket in one direction with the handle at the top. Make sure that it is properly inserted into the CPU socket before closing the rail frame plate. If it doesn't close properly, do not force it as it may damage your CPU. Instead, open the rail frame plate again, and double-check that the CPU is aligned properly.

7. Lift up the rail frame till it securely rests in upright position. Then remove the PnP cover cap from the CPU socket below. Grip the two lift tabs marked "Remove" at the middle of the cap and pull vertically upwards to remove the PnP cover cap.

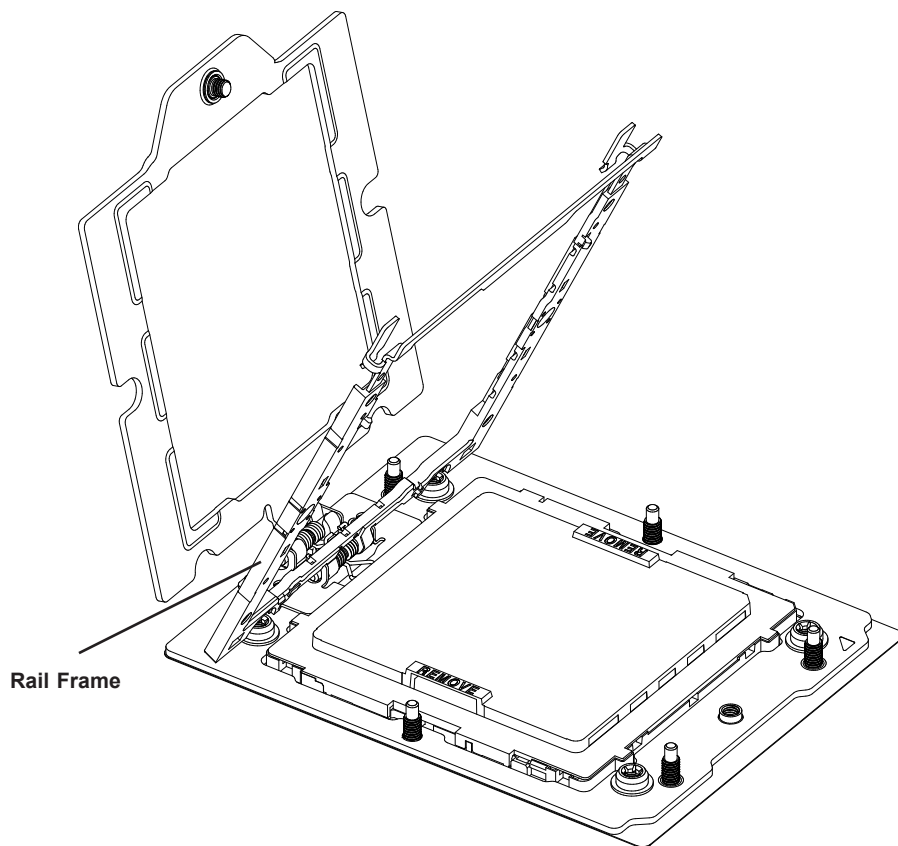

Important: The exposed socket contacts are extremely vulnerable and can be damaged easily. Do not touch or drop objects onto the contacts and be careful removing the PnP cover cap and when placing the rail frame over the socket.

8. Gently lower the rail frame down onto the socket until the latches on the rail frame engage with the socket housing and it rests in place. **DO NOT** force it into place!

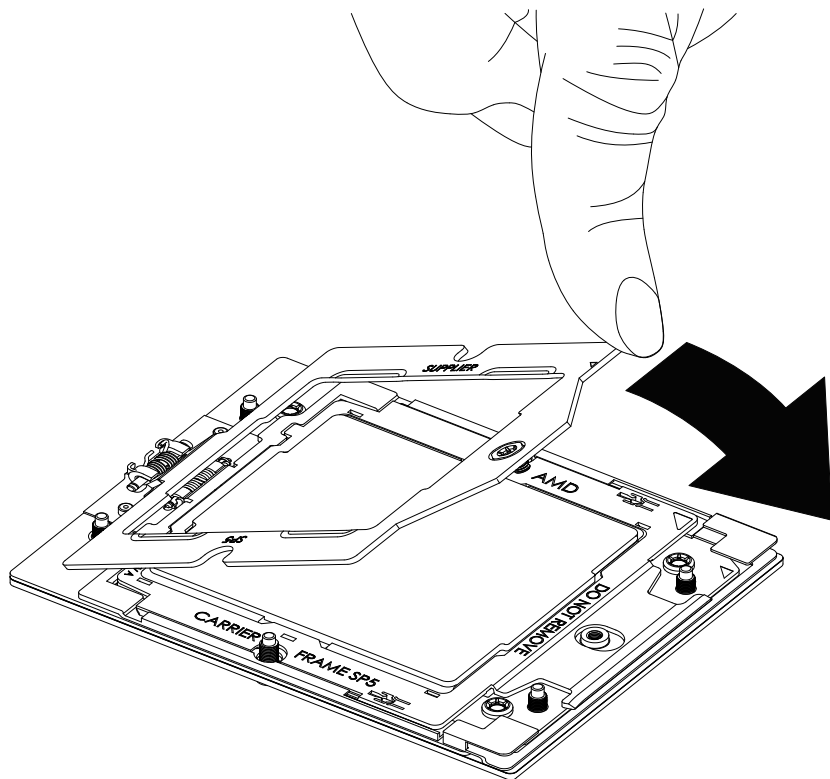

9. The force frame is spring loaded and has to be held in place before it is secured.
Important: Use a torque screwdriver, set it at 12.5~15.0 kgfcm (10.85~13.01 lbf-in) with a Torx T20 screw head bit, to prevent damage to the CPU.

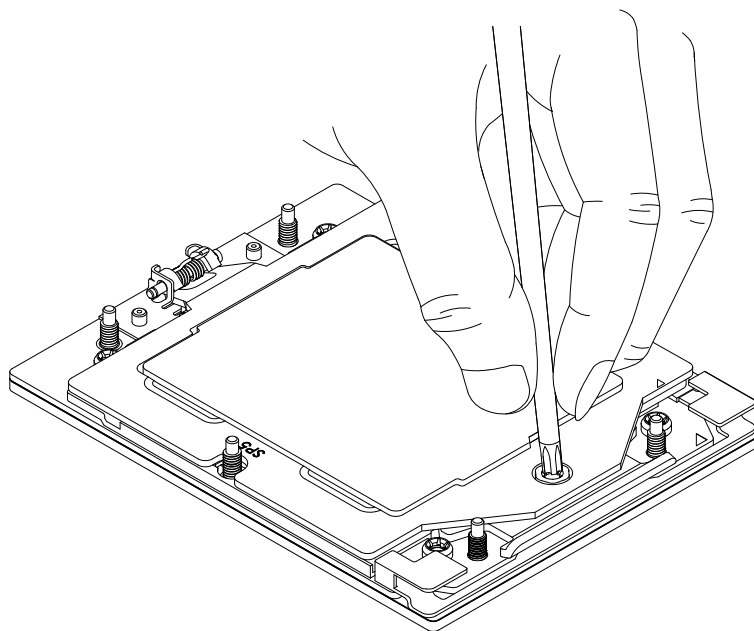

10. Place and re-screw the screw in the middle to the way you removed it. When finished, the force frame will be secure over both the rail frame and CPU package.

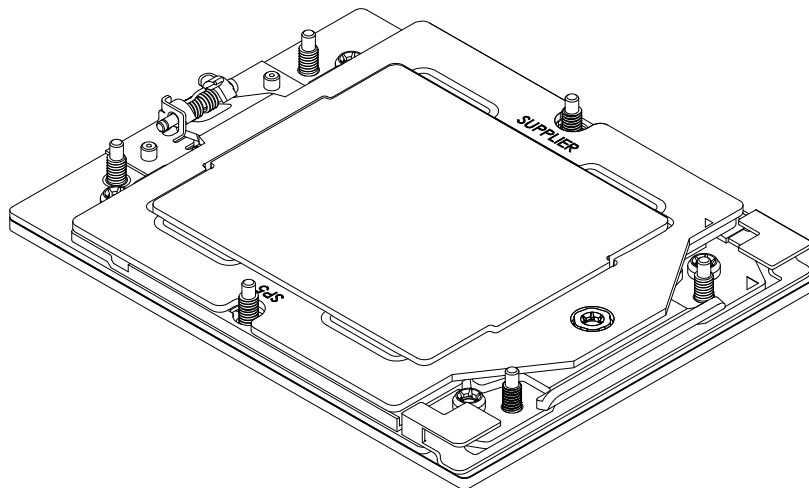

11. After the force frame is secured and the CPU package is in place, now you must install the heatsink to the frame. Lower the heatsink down till it rests securely over the six screw holes on CPU package on the socket frame.

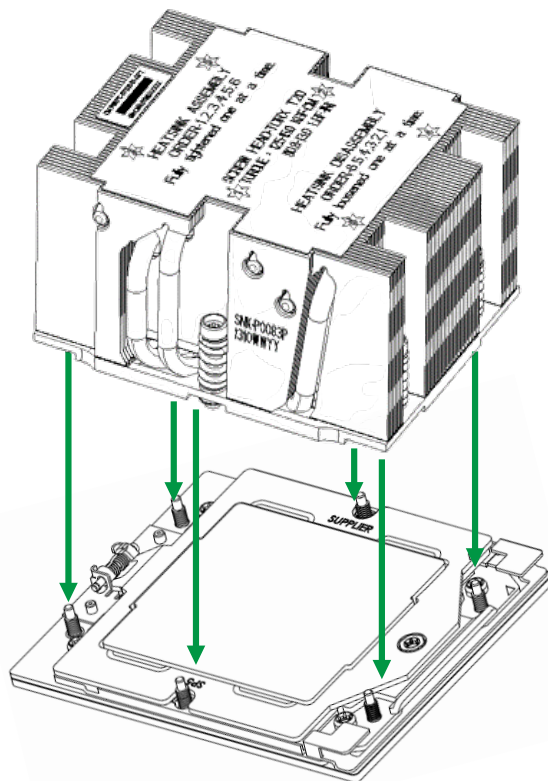

- Using a diagonal pattern, tighten the six screws down on the heatsink in a clockwise fashion till it is secure. The heatsink will now be secured and you have finished installing the processor and heatsink onto the motherboard. Repeat this procedure for any remaining CPU sockets on the motherboard.

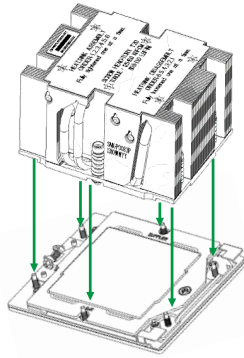

Un-installing the Processor and Heatsink

1. Remove the heatsink attached to the top of the CPU package by reversing the installation procedure.
2. Clean the thermal grease left by the heatsink on the CPU package lid to limit the risk of it contaminating the CPU package land pads or contacts in the socket housing.
3. Unscrewing the plate and lift the force frame to the vertical position.
4. Lift the rail frame using the lift tabs near the front end of the rail frame. Note that the rail frame is spring loaded, so be careful lifting it up into a vertical position.
5. Grip the handle of the carrier frame and pull upwards to extract it from the rail frame. Return the carrier frame/CPU package to its original shipping container.
6. Grip the handle on the external cap and return it to the rail frame sliding it downwards till it rests in the frame.
7. Gripping the rail frame, rotate it downwards till it rests above and locks over the socket housing in its horizontal position.
8. Push and rotate down the force frame till it is over the external cap and rail frame into a horizontal position.
9. While holding down the force frame, secure it back to the socket frame by securing screw #1 in place.

3.4 Memory Support and Installation

Note: Check the Supermicro website for recommended memory modules.

Important: Exercise extreme care when installing or removing DIMM modules to prevent any possible damage.

Memory Support

The H13SSW supports up to 3 TB of ECC DDR5 6400 MT/s speed (motherboard revision 2.01 or later is required), RDIMM/3DS memory in 12 slots. Refer to the tables below for additional memory information.

Note: Check the Supermicro website for possible updates to memory support. Please refer to Supermicro FAQ #41217 to identify the revision of your motherboard:

<https://www.supermicro.com/support/faqs/faq.cfm?faq=41217>

DIMM Population Guide														
Type	Channel													Nodes per Socket (NPS) Supported
	F1	E1	D1	C1	B1	A1	CPU	G1	H1	I1	J1	K1	L1	
CPU1 & 1 DIMM						V								NPS1
CPU1 & 2 DIMM						V		V						NPS2, NPS1
CPU1 & 4 DIMM*				V		V		V		V				NPS4, NPS2, NPS1
CPU1 & 6 DIMM				V	V	V		V	V	V				NPS2, NPS1
CPU1 & 8 DIMM		V		V	V	V		V	V	V		V		NPS4, NPS2, NPS1
CPU1 & 10 DIMM		V	V	V	V	V		V	V	V	V	V		NPS2, NPS1
CPU1 & 12 DIMM	V	V	V	V	V	V		V	V	V	V	V	V	NPS4, NPS2, NPS1

Note: Fully populate the motherboard with validated memory modules to achieve the best memory performance. Configure the NPS settings based on your applications. Selecting Auto in BIOS will default to NPS1.

Populating RDIMM/RDIMM 3DS DDR5 Memory Modules with AMD EPYC™ 9004 Series Processor			
DIMM Type	DIMM Population	Maximum Frequency (MT/s)	
	DIMM1	5600 MT/s Grade DIMM	4800 MT/s Grade DIMM
RDIMM	1R (1 rank)	4800	4800
	2R (2 ranks)	4800	4800
3DS RDIMM	2S2R (4 ranks)	4800	4800
	2S4R (8 ranks)	4800	4800

Populating RDIMM/RDIMM 3DS DDR5 Memory Modules with AMD EPYC™ 9005 Series Processor (Motherboard revision 2.00 or later is required)					
Type	DIMM Population	Maximum Frequency (MT/s)			
	DIMM1	6400 MT/s Grade DIMM		5600 MT/s Grade DIMM	4800 MT/s Grade DIMM
		MB Rev 2.01 or later	MB Rev 2.00		
RDIMM	1R	6400	6000	5600	4800
	2R	6400	6000	5600	4800
3DS RDIMM	2S2R (4 ranks)	6400	6000	5600	4800
	2S2R (8 ranks)	6400	6000	5600	4800

Note: 6400 MT/s memory speed requires motherboard revision 2.01 or later and performance may vary depending on the DIMM model. Please use Supermicro validated memory. Contact a Supermicro representative for more details.

DIMM Module Population Sequence

There is no specific order or sequence required when installing memory modules. However do keep the following in mind:

- Mixed DIMM speeds can be installed. However, all DIMMs will run at the speed of the slowest DIMM.
- The motherboard will support odd-numbered modules (1 or 3 modules installed). Populating with an even number of DIMMs will result in interleaved memory. However, to achieve the best memory performance, fully populate the motherboard with validated memory modules.

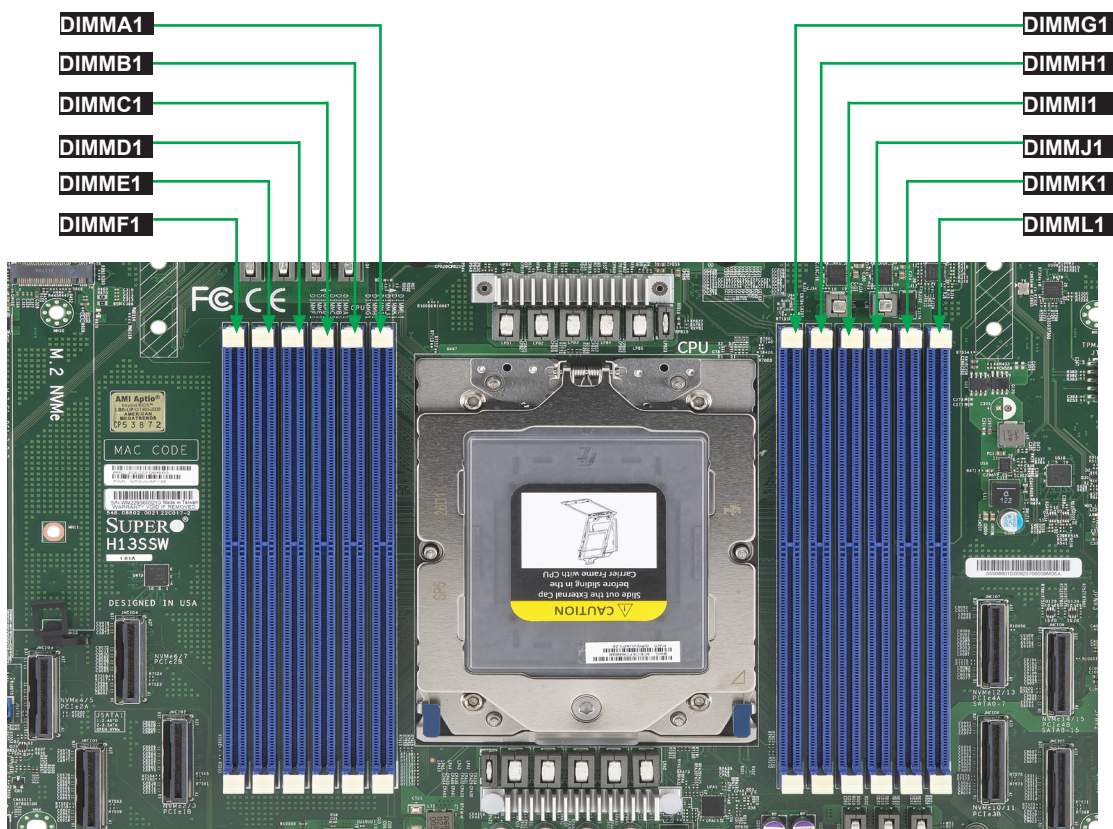
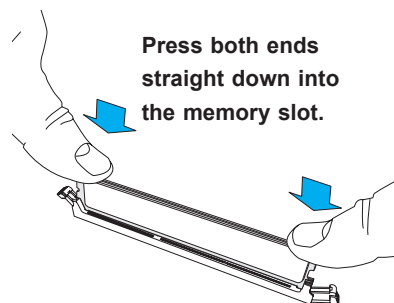
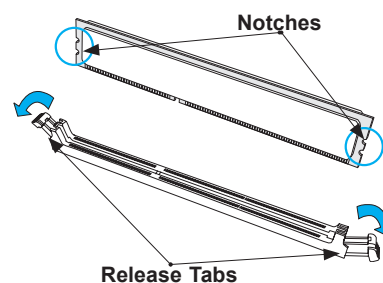
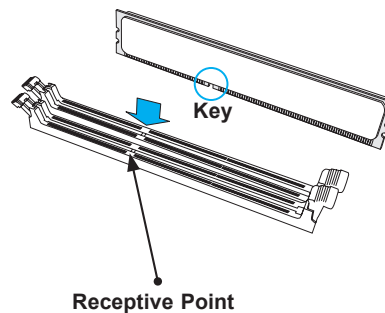

Figure 3-2. DIMM Numbering

DIMM Installation

1. Insert the desired number of DIMMs into the memory slots. See [Memory Support](#) for details on memory population guidelines.
2. Push the release tabs outwards on both ends of the DIMM slot to unlock it.
3. Align the key of the DIMM module with the receptive point on the memory slot.
4. Align the notches on both ends of the module against the receptive points on the ends of the slot.
5. Press both ends of the module straight down into the slot until the module snaps into place.
6. Press the release tabs to the lock positions to secure the DIMM module into the slot.



DIMM Removal

Press both release tabs on the ends of the DIMM module to unlock it. Once the DIMM module is loosened, remove it from the memory slot.

3.5 Motherboard Battery

The motherboard uses non-volatile memory to retain system information when system power is removed. This memory is powered by a lithium battery residing on the motherboard.

Replacing the Battery

Begin by [removing power](#) from the system.

1. Push aside the small clamp that covers the edge of the battery. When the battery is released, lift it out of the holder.
2. To insert a new battery, slide one edge under the lip of the holder with the positive (+) side facing up. Then push the other side down until the clamp snaps over it.

Note: Handle used batteries carefully. Do not damage the battery in any way; a damaged battery may release hazardous materials into the environment. Do not discard a used battery in the garbage or a public landfill. Please comply with the regulations set up by your local hazardous waste management agency to dispose of your used battery properly.

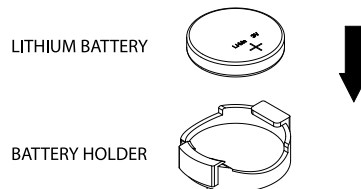

Figure 3-3. Installing the Onboard Battery

Important: There is a danger of explosion if the onboard battery is installed upside down (which reverses its polarities). This battery must be replaced only with the same or an equivalent type recommended by the manufacturer (CR2032).

3.6 Storage Drives

The system supports 12 hot-swap 3.5"/2.5" SAS/SATA/NVMe storage drives in hybrid bays. An optional controller card kit is required to support SAS. Optional cables are required to support NVMe.

The drives are mounted in tool-less drive carriers that simplify their removal from the chassis. These carriers also help promote proper airflow. Each carrier has a small space on the front to receive a label, orange or purple, to help distinguish SAS/SATA/NVMe from other protocols.

Note: Enterprise level hard disk drives are recommended for use in Supermicro servers. For compatible storage drives, see the [H13SSW motherboard web page](#).

Installing Drives



Figure 3-4. Logical Drive Numbers

Removing a Hot-Swap Drive Carrier from the Chassis

1. Push the release button on the drive carrier, which will extend the drive carrier handle.
2. Use the drive carrier handle to pull the drive out of the chassis.

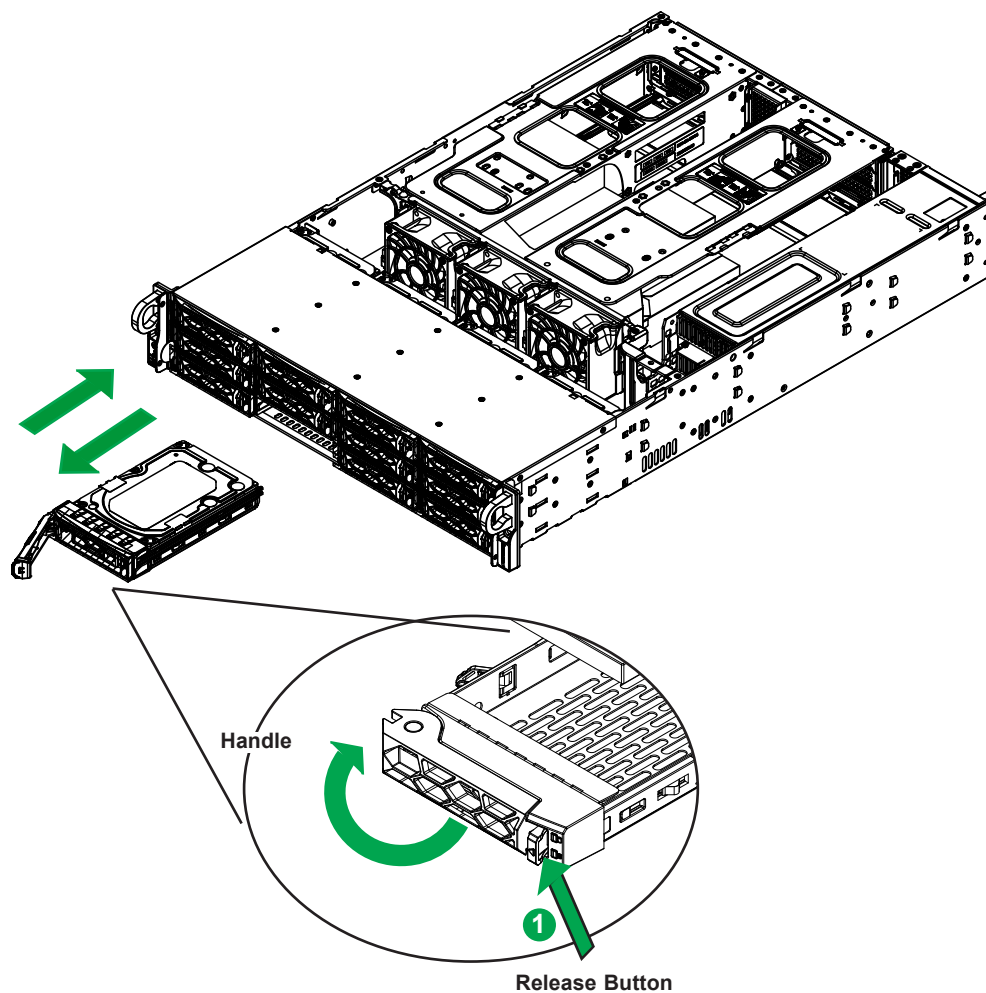

Figure 3-5. Removing a Drive Carrier

Installing a Drive

1. Install the drive directly into the tray with four screws underneath.
2. Insert the drive carrier into its bay, keeping the release button on the right. When the carrier reaches the rear of the bay, the release handle will retract.
3. Push the handle in until it clicks into its locked position.

3.5" Drive

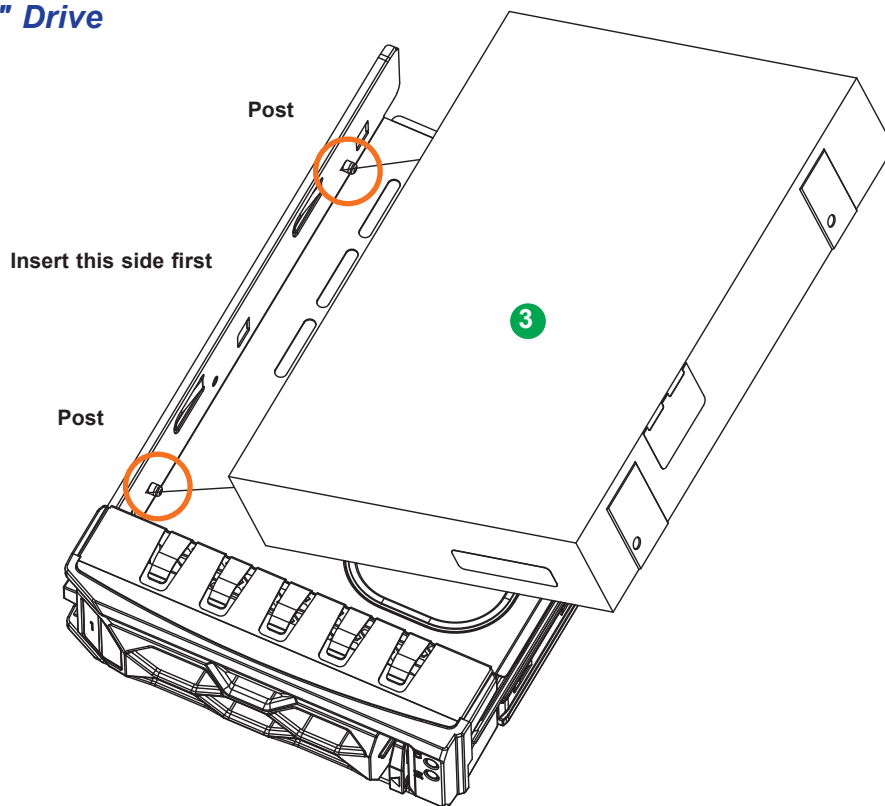

Figure 3-6. Installing a 3.5" Drive into a Carrier

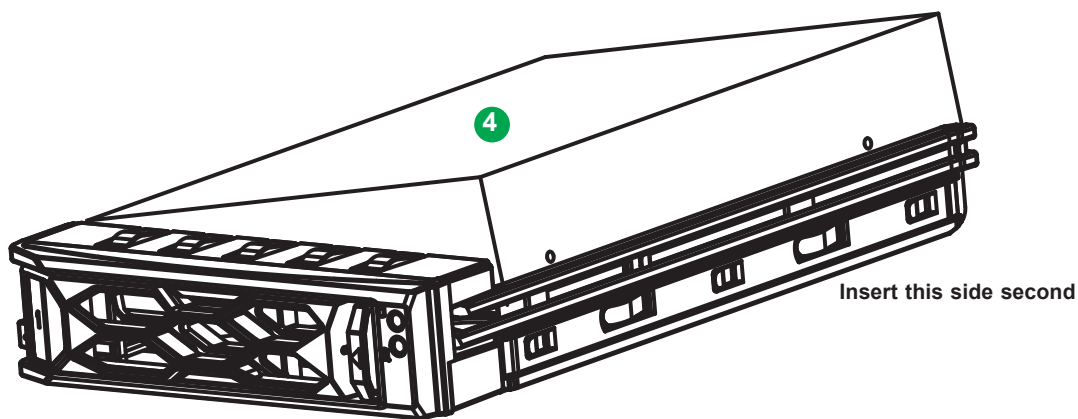

Figure 3-7. Installing a 3.5" Drive into a Carrier

Installing a 2.5" Drive

1. Install the drive directly into the tray with four screws underneath.
2. Insert the drive carrier into its bay, keeping the release button on the right. When the carrier reaches the rear of the bay, the release handle will retract.
3. Push the handle in until it clicks into its locked position.

2.5" Drive

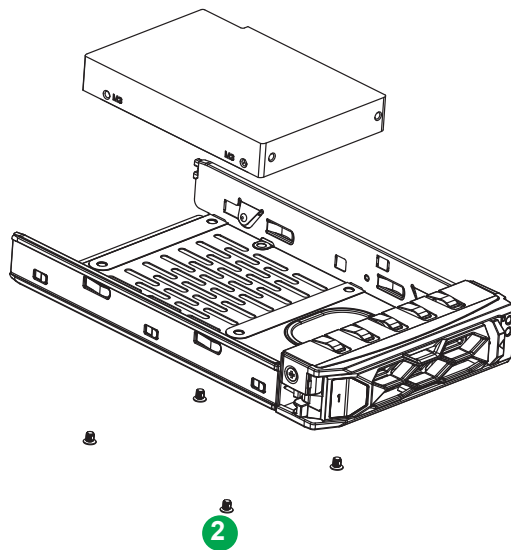

Figure 3-8. Installing a 2.5" Drive into a Carrier

Installing M.2 Solid State Drives

The motherboard supports two PCIe 3.0 M.2 slots in the M-Key 2280/22110 form factor.

Important: Use industry-standard anti-static equipment, such as gloves or wrist strap, and follow precautions to avoid damage caused by ESD.

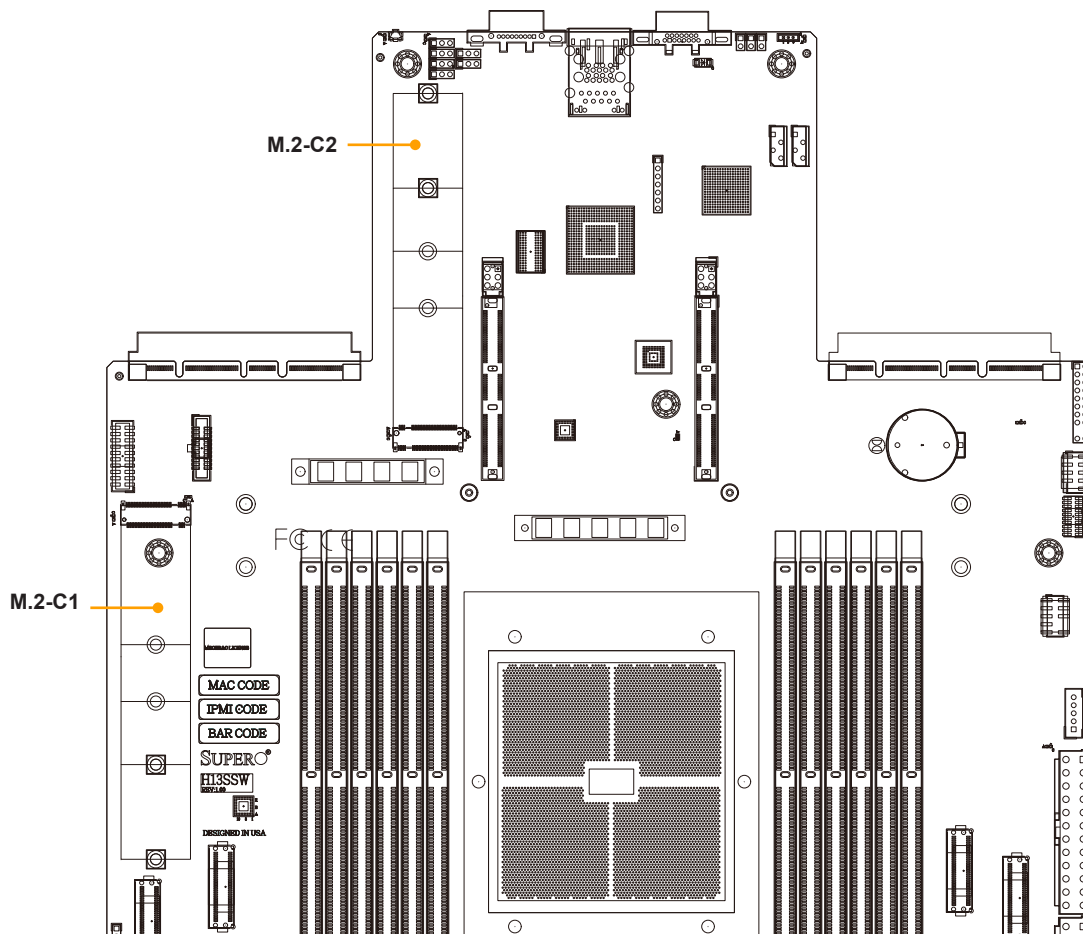

Figure 3-9. Installing a 3.5" Drive into a Carrier

Installing an M.2 SSD

1. Locate the M.2 socket on the motherboard (M.2-C1 or M.2-C2).
2. Next locate the M.2 hole containing a plastic pin.
3. If needed, move the plastic pin to the M.2 hole that supports the 2280 SSD.
4. Insert the M.2 SSD into the socket and secure the SSD with the plastic pin.

3.7 System Cooling

Fans

Three 4-cm fans provide the cooling for the system. Make sure the chassis makes a good seal so the cooling air circulates properly through the chassis.

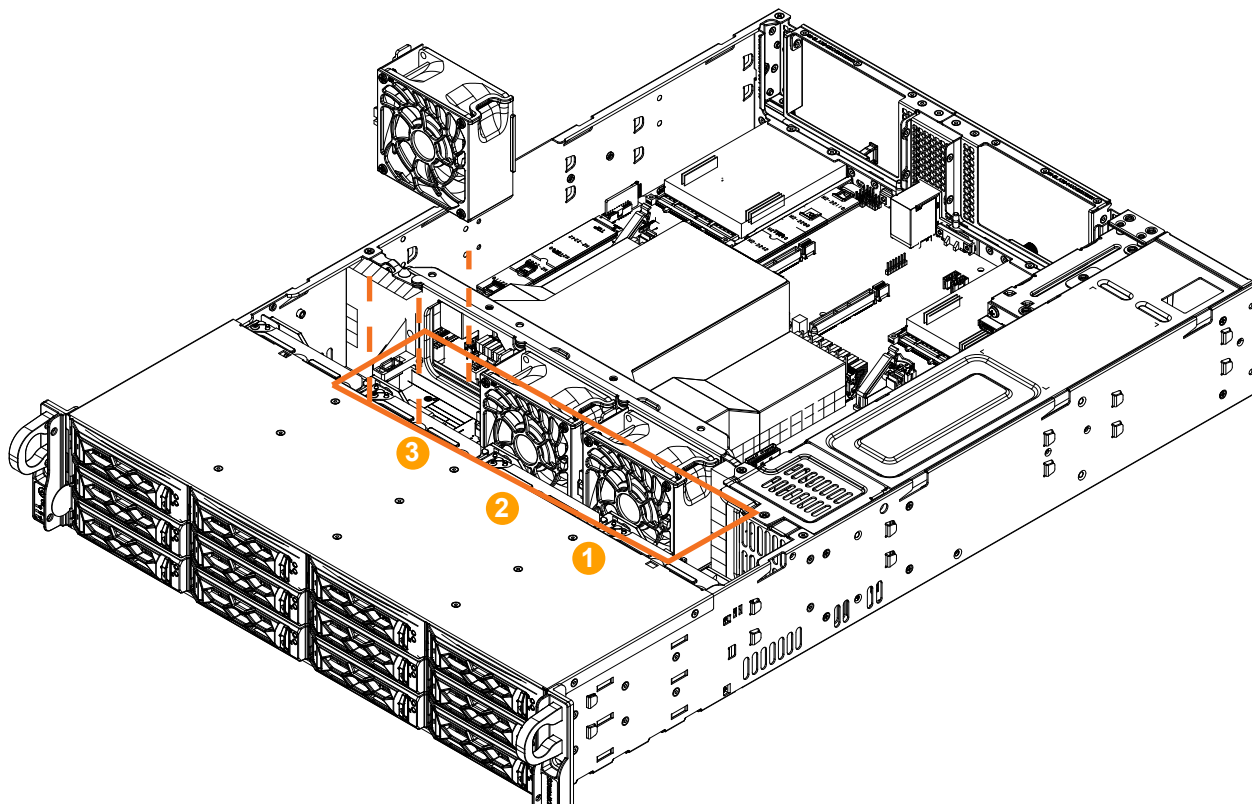

Figure 3-10. Fan Positions

Changing a System Fan

1. Determine which fan is failing. If possible, use the BMC. Remove the chassis lid to examine the fans.
2. Push the release latch, and lift the fan up from the housing and out of the chassis.
3. Push the fan up from the bottom and out of the top of the housing.
4. Place the replacement fan into the vacant space in the housing while checking the proper orientation. Push it until the latch clicks and the fan is secure.
5. Confirm the fans are working properly before closing the chassis lid.

Air Shrouds

Air shrouds concentrate airflow to maximize fan efficiency. They do not require screws to install.

Installing the Standard Air Shrouds

- Position the air shrouds as illustrated in the figure below, sliding the front over the edge of the fan tray.

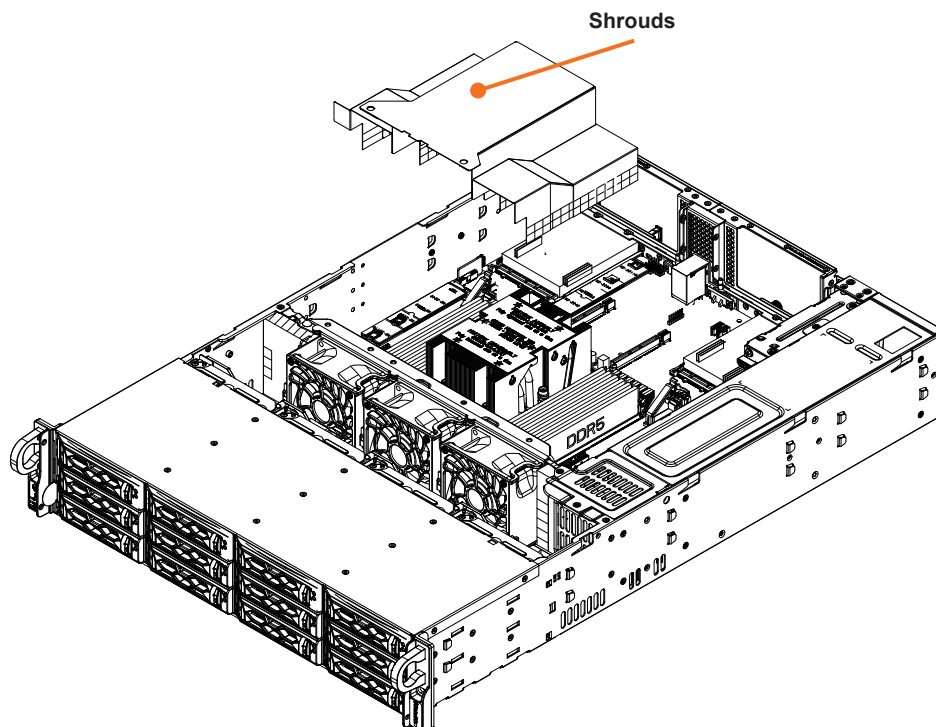

Figure 3-11. Installing the Air Shrouds

3.8 Power Supply

The chassis features redundant power supplies. The system will continue to operate if one module fails. It should be replaced as soon as possible. The power supply modules are hot-swappable, meaning they can be changed without powering down the system. New units can be ordered directly from Supermicro or authorized distributors.

These power supplies are auto-switching capable. This feature enables them to automatically sense the input voltage and operate at a 100-120 v or 180-240 v.

Power Supply LEDs

On the rear of the power supply module, an LED displays the status.

- **Solid Green:** When illuminated, indicates that the power supply is on.
- **Blinking Green:** When blinking, indicates that the power supply is plugged in and turned off by the system.
- **Blinking Amber:** When blinking, indicates that the power supply has a warning condition and continues to operate.
- **Solid Amber:** When illuminated, indicates that the power supply is plugged in, and is in an abnormal state. The system might need service. Please contact Supermicro technical support.

Changing the Power Supply Module:

1. Unplug the AC cord from the module to be replaced.
2. On the back of the module, push the release tab sideways.
3. Pull the module out using the handle.
4. Push the new power supply module into the power bay until it clicks. Replace with the same model.
5. Plug the AC power cord back into the module.



Figure 3-12. Replacing the Power Supply

3.9 AIOM Cards

The system supports up to two advanced input/output module (AIOM) network port cards.

AIOM Configurations		
Slot	Mechanical	Electrical
A1	Small Form Factor, OCP 3.0	PCIe 5.0 x16
A2	Small Form Factor, OCP 3.0	PCIe 5.0 x16



Figure 3-13. AIOM Chassis Slots

Installing an AIOM Card

1. Remove the blank cover plate (**A1** or **A2**), by unscrewing the thumbscrew.
2. Slide the AIOM card in the opening until it seats in the motherboard slot.
3. Secure with the thumbscrew.

Note: System power must be turned off before removing or installing AIOM cards.

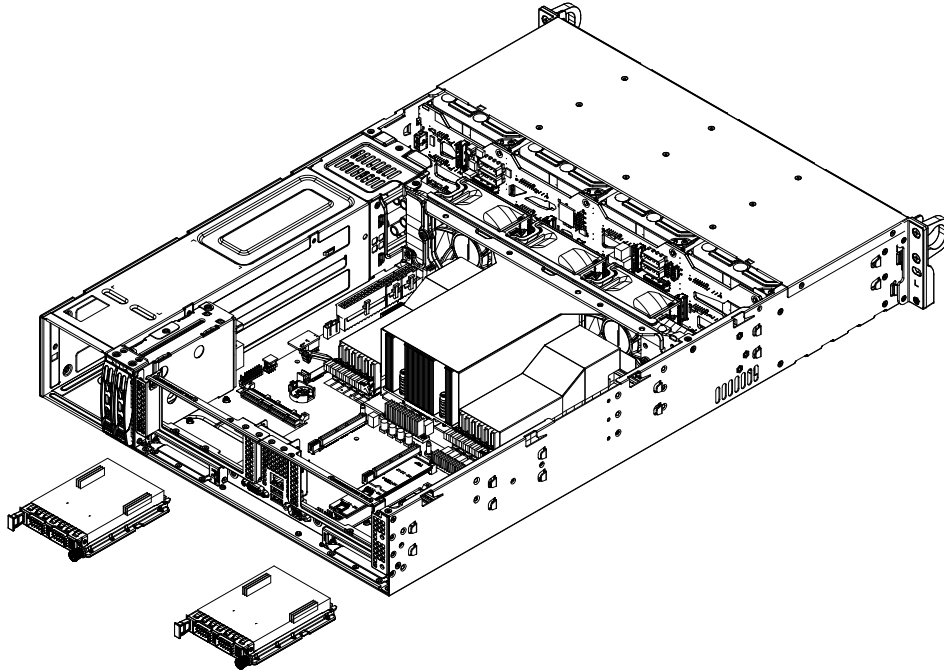

Figure 3-14. Installing AIOMs

3.10 PCIe Expansion Cards

The system accepts six full-height, half-length expansion cards, mounted on riser cards and brackets.

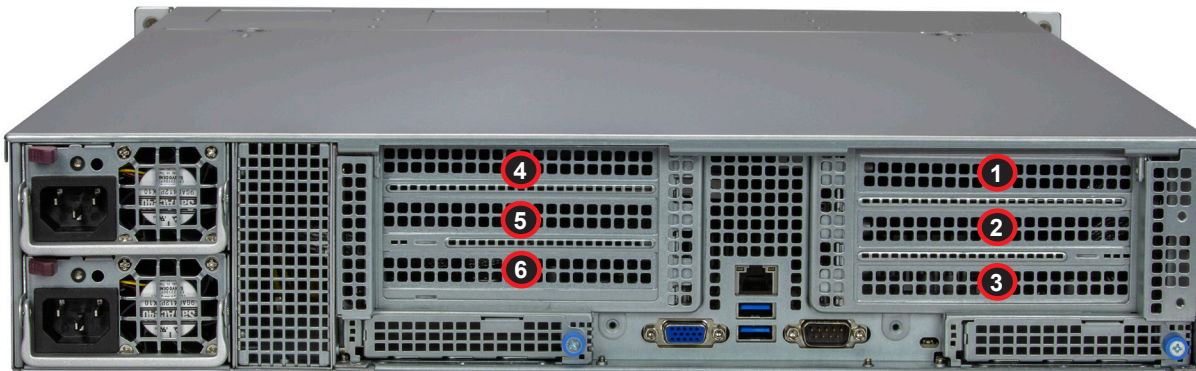

Figure 3-15. Expansion Card Slots in the Chassis

12 SATA only or 12 SATA/4NVME Hybrid

Expansion Card Slots	
Slot	Description
1	PCIe 5.0 x16 slot (FHFL)
2	PCIe 5.0 x8 slot (FHFL) (optional)*
3	PCIe 5.0 x16 slot (FHHL)
4	PCIe 5.0 x8 slot (FHFL) (optional)*
5	PCIe 5.0 x16 slot (FHFL)
6	PCIe 5.0 x16 slot (FHHL)

* PCIe slots 2 and 4 are not available with NVMe drive option.

12 SATA/12 NVMe Hybrid

Expansion Card Slots	
Slot	Description
1	PCIe 5.0 x16 slot (FHFL)
6	PCIe 5.0 x16 slot (FHHL)

12 NVMe

Expansion Card Slots	
Slot	Description
3	PCIe 5.0 x16 slot (FHHL)
4	PCIe 5.0 x8 slot (FHFL) (optional)*
6	PCIe 5.0 x16 slot (FHHL)

Installing an Expansion Card

1. Power down the system as described in section 3.1 and remove the cover.
2. Pull the riser bracket up and out using the pull-tabs.

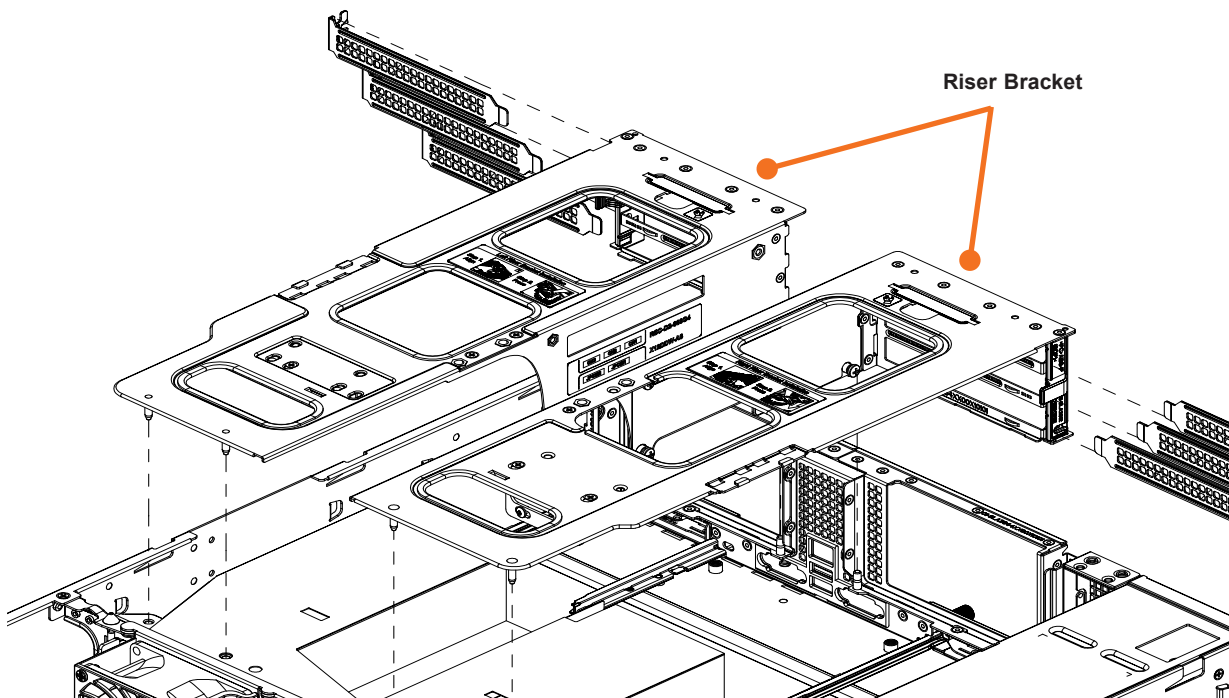

Figure 3-16. Riser Card Bracket and Expansion Slots

3. Insert the expansion card into a slot on the riser card while aligning the expansion card backplate with the open slot in the rear of the chassis. Flip the small plastic lever to secure the backplate.
4. Insert the riser card into the motherboard expansion slot while aligning the riser card bracket with the rear of the chassis. There are two guide pins on the rear of the riser bracket, and one guide pin on the motherboard.

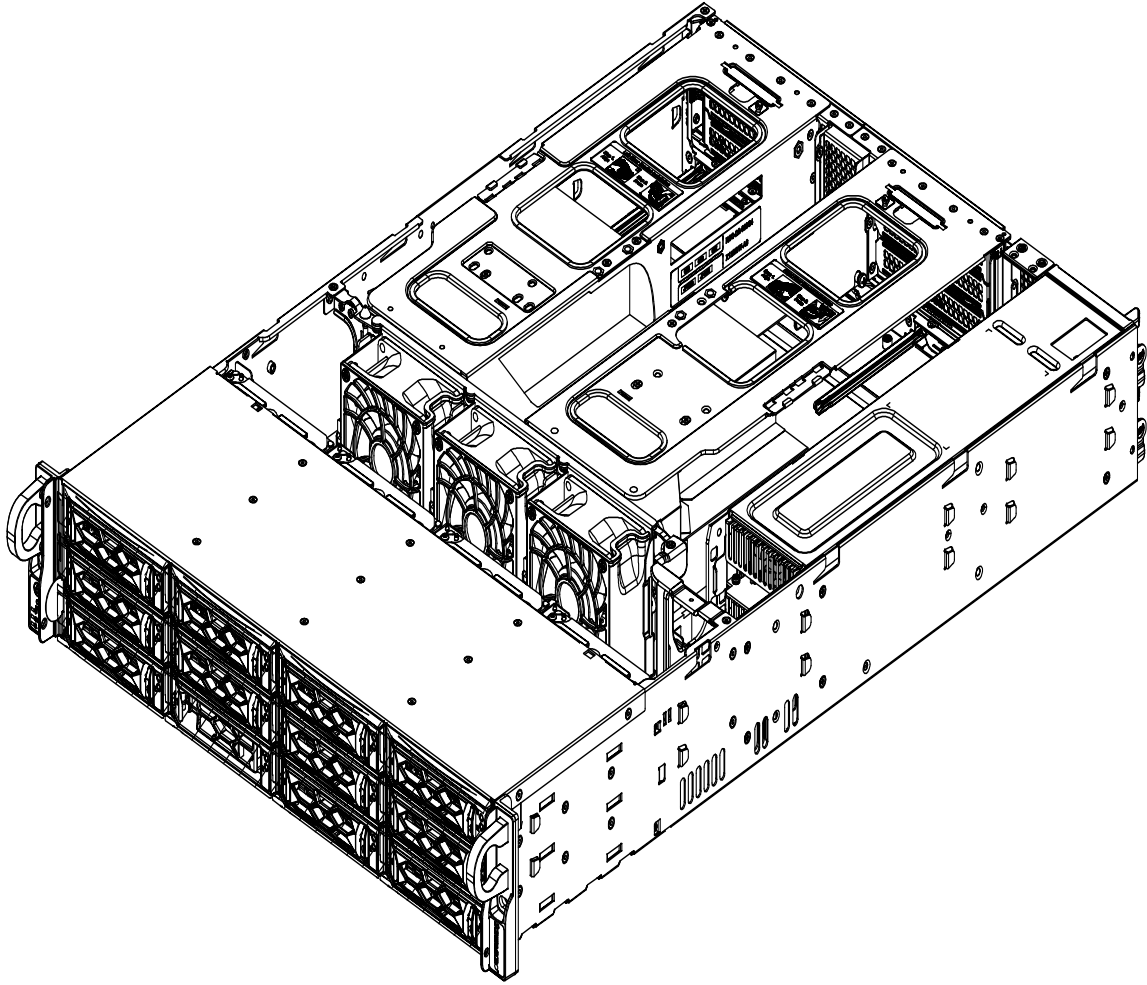

Figure 3-17. Example Expansion Cards

3.11 Cable Routing

Use this section to route or reroute cables. Proper routing is important to maintain airflow through the system.

Cable part numbers and descriptions are available at the [Online Cable Matrix](#).

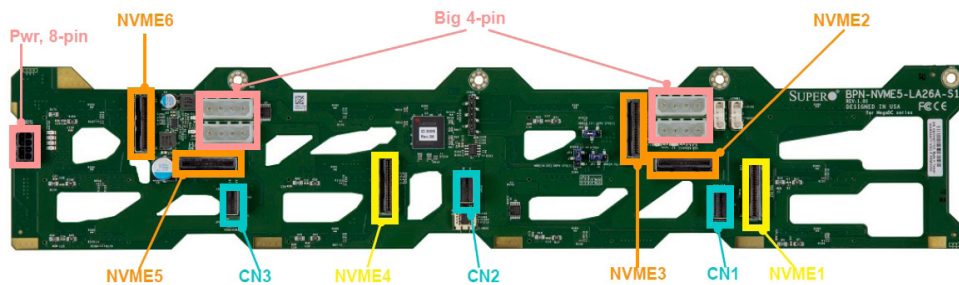

Figure 3-18. Backplane Cable Routing Diagram
Backplane BPN-NVME5-LA26A-S12

12x SATA + 4 PCIe x16



Front cables

	Cable	Description	BPN/Riser and Port	MB Port
5	CBL-MCIO-124354Y	SATA 0-3	BP CN1	JMCIO7
		SATA 4-7	BP CN2	
6	CBL-MCIO-1227EQS4	SATA 8-11	BP CN3	JMCIO8

Rear PCIe Cable

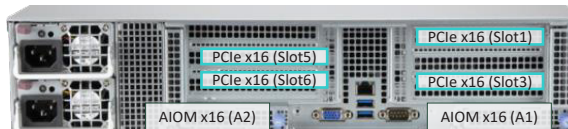

	Cable	Description	BPN/Riser and Port	MB Port
9	NA	RSC-D2-666G5 PCIe x16(Slot 3)	Gold Finger	JLWIO2
1	CBL-MCIO-1339M5R	RSC-D2-666G5 PCIe x16(Slot 1)	CN4	JMCIO3
2	CBL-MCIO-1339M5R	RSC-D2-666G5 PCIe x16(Slot 1)	CN3	JMCIO4
10	NA	RSC-D2R-666G5 PCIe x16(Slot 6)	Gold Finger	JRWIO2
7	CBL-MCIO-1339M5R	RSC-D2R-666G5 PCIe x16(Slot 5)	CN1	JMCIO5
8	CBL-MCIO-1339M5R	RSC-D2R-666G5 PCIe x16(Slot 5)	CN2	JMCIO6

Require to install at least 1 AIOM NIC in slot A1

Figure 3-19. Cable Routing Diagram (12x SATA + 4 PCIe x16)

12x SATA + 4 PCIe x16 + Optional 2 PCIe x8



Front cables

	Cable	Description	BPN/Riser and Port	MB Port
5	CBL-MCIO-1243S4Y	SATA 0-3	BP CN1	JMCIO7
		SATA 4-7	BP CN2	
6	CBL-MCIO-1227EQS4	SATA 8-11	BP CN3	JMCIO8

Rear PCIe Cable

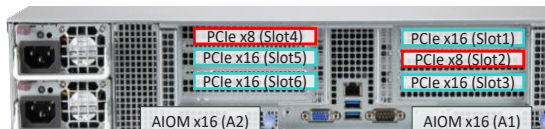

	Cable	Description	BPN/Riser and Port	MB Port
9	NA	RSC-D2-666G5 PCIe x16(Slot 3)	Gold Finger	JLWIO2
1	CBL-MCIO-1339M5R	RSC-D2-666G5 PCIe x16(Slot 1)	CN4	JMCIO3
2			CN3	JMCIO4
10	NA	RSC-D2R-666G5 PCIe x16(Slot 6)	Gold Finger	JRWIO2
7	CBL-MCIO-1339M5R	RSC-D2R-666G5 PCIe x16(Slot 5)	CN1	JMCIO5
8			CN2	JMCIO6
3	CBL-MCIO-1339M5R	RSC-D2-666G5 PCIe x8(Slot 2)	CN1	JMCIO1
4	CBL-MCIO-1339M5R	RSC-D2R-666G5 PCIe x8(Slot 4)	CN4	JMCIO2

Require to install at least 1 AIOM NIC in slot A1
PCIe slot 2 and 4 are optional

Figure 3-20. Cable Routing Diagram (12x SATA + 4 PCIe x16 + Optional 2 PCIe x8)

12x SATA/4x NVMe Hybrid, 4x PCIe x16



Front cables

	Cable	Description	BPN/Riser and Port	MB Port
5	CBL-MCIO-1243S4Y	SATA 0-3	BP CN1	JMCIO7
		SATA 4-7	BP CN2	
6	CBL-MCIO-1227EQS4	SATA 8-11	BP CN3	JMCIO8
3	CBL-MCIO-1232M5	NVMe 0-1	BP NVMe1	JMCIO1
4	CBL-MCIO-1232M5	NVMe 2-3	BP NVMe2	JMCIO2

Rear PCIe Cable

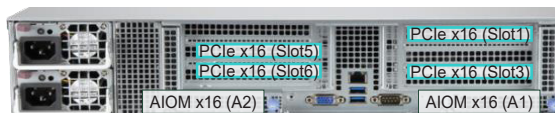

	Cable	Description	BPN/Riser and Port	MB Port
9	NA	RSC-D2-666G5 PCIe x16(Slot 3)	Gold Finger	JLWIO2
4	CBL-MCIO-1339M5R	RSC-D2-666G5 PCIe x16(Slot 1)	CN4	JMCIO3
2	CBL-MCIO-1339M5R	RSC-D2-666G5 PCIe x16(Slot 1)	CN3	JMCIO4
10	NA	RSC-D2R-666G5 PCIe x16(Slot 6)	Gold Finger	JRWIO2
7	CBL-MCIO-1339M5R	RSC-D2R-666G5 PCIe x16(Slot 5)	CN1	JMCIO5
8	CBL-MCIO-1339M5R	RSC-D2R-666G5 PCIe x16(Slot 5)	CN2	JMCIO6

Require to install at least 1 AIOM NIC in slot A1

Figure 3-21. Cable Routing Diagram (12x SATA/4x NVMe Hybrid, 4x PCIe x16)

12 NVMe + 2x PCIe x16



Front cables

	Cable	Description	BPN/Riser and Port	MB Port
3	CBL-MCIO-1232M5	NVMe 0-1	BP NVMe1	JMCI01
4	CBL-MCIO-1232M5	NVMe 2-3	BP NVMe2	JMCO2
1	CBL-MCIO-1232M5	NVMe 4-5	BP NVMe3	JMCO3
2	CBL-MCIO-1339M5R	NVMe 6-7	BP NVMe4	JMCO4
8	CBL-MCIO-1232M5	NVMe 8-9	BP NVMe5	JMCO5
7	CBL-MCIO-1232M5	NVMe 10-11	BP NVMe6	JMCO6

Rear PCIe Cable

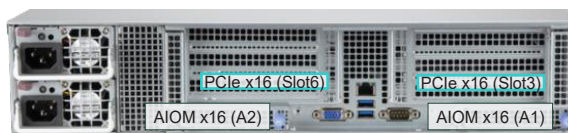

	Cable	Description	BPN/Riser and Port	MB Port
9	NA	RSC-D2-666G5 PCIe x16(Slot 3)	Gold Finger	JLWIO2
10	NA	RSC-D2R-666G5 PCIe x16(Slot 6)	Gold Finger	JRWIO2

Require to install at least 1 AIOM NIC in slot A1

Figure 3-22. Cable Routing Diagram (12 NVMe + 2x PCIe x16)

Chapter 4

Motherboard Connections

This section describes the jumpers, connections and LEDs on the motherboard and provides pinout definitions. Some connections might not be used in this system. A motherboard layout indicating component locations may be found in [Chapter 1](#). More details can be found in the [Motherboard Manual](#).

4.1 Power Connections

12 V 8-pin Auxiliary Power Connector (JPWR2)

JPWR2 is an 8-pin ATX power input to provide auxiliary power to the processor. Refer to the table below for pin definitions.

12 V 8-pin Power Connector Pin Definitions			
Pin#	Definition	Pin#	Definition
1	Ground	5	+12 V
2	Ground	6	+12 V
3	Ground	7	+12 V
4	Ground	8	+12 V

Main Power Supply Connector (JPWR3)

The primary power supply connector (JPWR3) is an ATX power connector that the power supply plugs into directly.

ATX Power 24-pin Connector Pin Definitions			
Pin#	Definition	Pin#	Definition
1	+3.3 V	13	+3.3 V
2	+3.3 V	14	-12 V
3	Ground	15	Ground
4	+5 V	16	PS_ON
5	Ground	17	Ground
6	+5 V	18	Ground
7	Ground	19	Ground
8	PWR_OK	20	Res (NC)
9	5 VSB	21	+5 V
10	+12 V	22	+5 V
11	+12 V	23	+5 V
12	+3.3 V	24	Ground

4.2 Headers and Connectors

NVMe Ports (NVMe 0~11)

The H13SSW has twelve NVMe ports (2 ports per 1 MCIO x8) on the motherboard. These ports provide high speed and low latency directly from the CPU to NVMe Solid State (SSD) drives. This greatly increases SSD data-throughput performance and significantly reduces PCIe latency by simplifying driver/software requirements resulting from direct PCIe interface from the CPU to the NVMe SSD drives.

SATA/NVMe Hybrid Ports (NVMe12~15, SATA 0~15)

Each SATA/NVMe hybrid port can support up to eight SATA 3.0 ports or two NVMe ports (PCIe x4), for a total of 16 SATA ports or four NVMe ports.

PCIe M.2 Connectors (M.2-C1, M.2-C2)

The PCIe M.2 connectors are for devices such as memory cards, wireless adapters, etc. These devices must conform to the PCIe M.2 specifications (formerly known as NGFF). These particular PCIe M.2 connectors support M-Key (PCIe 3.0 x2) storage cards.

TPM/Port 80 Header

A Trusted Platform Module (TPM)/Port 80 header is located at JTPM1 to provide TPM support and Port 80 connection. Use this header to enhance system performance and data security. Refer to the table below for pin definitions. Please go to the following link for more information on the TPM: <http://www.supermicro.com/manuals/other/TPM.pdf>.

Trusted Platform Module Header Pin Definitions			
Pin#	Definition	Pin#	Definition
1	+3.3 V	2	SPI_CS#
3	RESET#	4	SPI_MISO
5	SPI_CLK	6	GND
7	SPI_MOSI	8	NC
9	+1.8 V Stdby	10	SPI_IRQ#

USB Ports (USB0/1)

There are a total of four USB ports supported on the motherboard. Two are located on the front panel, and two are located on the back panel.

Front Panel USB 0/1 (2.0) Pin Definitions			
Pin#	Definition	Pin#	Definition
1	+5 V	2	+5 V
3	USB7_N	4	USB8_N
5	USB7_P	6	USB8_P
7	Ground	8	Ground
9	Key	10	USB_OC#

Expansion Slots

The motherboard features several expansion slots. The table below describes each slot's type and speed.

Expansion Slots	
Name	Description
LWIO	Left-hand riser card slot supports PCIe 5.0 x16
RWIO	Right-hand riser card slot supports PCIe 5.0 x16
AIOM1	AIOM (Advanced I/O Module) supports PCIe 5.0 x16 (OCP 3.0 Compatible)
AIOM2	AIOM (Advanced I/O Module) supports PCIe 5.0 x16 (OCP 3.0 Compatible)

Onboard Battery (BT1)

The onboard back up battery is located at BT1. The onboard battery provides backup power to the on-chip CMOS, which stores the BIOS' setup information. It also provides power to the Real Time Clock (RTC) to keep it running.

Chassis Intrusion (JL1)

A Chassis Intrusion header is located at JL1 on the motherboard. Attach the appropriate cable from the chassis to the header to inform you when the chassis has been opened.

Chassis Intrusion Pin Definitions	
Pins	Definition
1	Intrusion Input
2	Ground

Power SMB Header (PWRI2C)

Power System Management Bus (I²C) header monitors power supply, fan and system temperatures. See the table below for pin definitions.

Power SMB Header Pin Definitions	
Pin#	Definition
1	Clock
2	Data
3	Alert
4	Ground
5	+3.3 V

4-pin External BMC I2C Header

A System Management Bus header for IPMI 2.0 is located at JIPMB1. Connect a cable to this header to use the IPMB I²C connection on your system. Refer to the table below for pin definitions.

External I ² C Header Pin Definitions	
Pin#	Definition
1	Data
2	Ground
3	Clock
4	+3.3 V Stdby

Control Panel

JF1 contains header pins for various control panel connections. See the figure below for the pin locations and definitions of the control panel buttons and LED indicators.

All JF1 wires have been bundled into a single cable to simplify this connection. Make sure the red wire plugs into pin 1 as marked on the motherboard. The other end connects to the control panel PCB board.

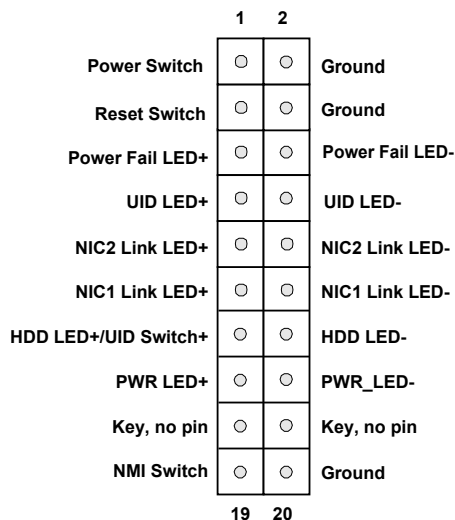

Figure 4-1. JF1 Control Panel Pins

NMI Button

The non-maskable interrupt button header is located on pins 19 and 20 of JF1. Refer to the table below for pin definitions.

NMI Button Pin Definitions (JF1)	
Pin#	Definition
19	NMI Switch
20	Ground

Power LED

The Power LED connection is located on pins 15 and 16 of JF1. Refer to the table below for pin definitions.

Power LED Pin Definitions (JF1)	
Pin#	Definition
15	PWR_LED+
16	PWR_LED-

Drive Activity LED

The Drive Activity LED connection is located on pins 13 and 14 of JF1. Attach a hard drive LED cable here to display disk activity detected on the motherboard's built-in disk controllers. See the table below for pin definitions.

Drive Activity LED Pin Definitions (JF1)	
Pin#	Definition
13	Drive Activity LED+/UID Switch+
14	Drive Activity_LED-

NIC1/NIC2 Link LED

The NIC (Network Interface Controller) LED connection for LAN port 1 is located on pins 11 and 12 of JF1, and the LED connection for LAN Port 2 is on pins 9 and 10. Attach the NIC LED cables to display network activity. Refer to the table below for pin definitions.

NIC1/NIC2 LED Pin Definitions (JF1)	
Pin#	Definition
9/11	NIC Link LED+
10/12	NIC Link LED-

UID LED

The UID LED is on pins 7 and 8 of JF1. Connect the front panel UID LED to this header to indicate when the rear UID switch is turned on. Refer to the table below for pin definitions.

UID LED Pin Definitions (JF1)	
Pin#	Definition
7	UID LED+
8	UID LED-

Power Fail LED

The Power Fail LED connection is located on pins 5 and 6 of JF1. Refer to the table below for pin definitions.

Power Fail LED Pin Definitions (JF1)	
Pin#	Definition
5	Power Fail LED+
6	Power Fail LED-

Reset Button

The Reset Button connection is located on pins 3 and 4 of JF1. Attach the hardware reset switch from the computer case to this header to reset the system. Refer to the table below for pin definitions.

Reset Button Pin Definitions (JF1)	
Pin#	Definition
3	Reset Switch
4	Ground

Power Button

The Power Button connection is located on pins 1 and 2 of JF1. Momentarily contacting both pins will power on/off the system. This button can also be configured to function as a suspend button (with a setting in the BIOS - see Chapter 4). To turn off the power in the suspend mode, press the button for at least 4 seconds. Refer to the table below for pin definitions.

Power Button Pin Definitions (JF1)	
Pin#	Definition
1	Power Switch
2	Ground

4.3 Input/Output Ports

See Figure 4-2 below for the locations and descriptions of the various I/O ports on the rear of the motherboard.

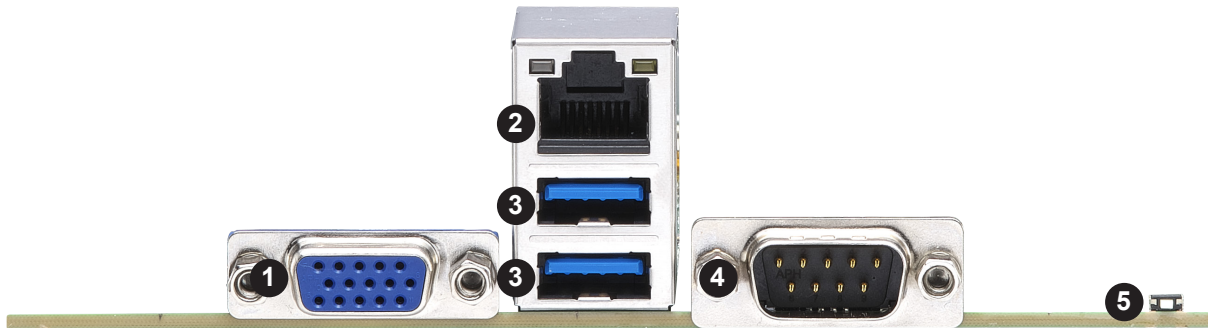

Figure 4-2. I/O Port Locations and Definitions

Rear I/O Ports			
#	Description	#	Description
1	VGA Port	4	COM Port
2	IPMI LAN Port	5	UID Switch & UID LED
3	USB Ports (USB 3.0)		

1. VGA Port

There is one VGA port on the rear I/O panel.

2. IPMI LAN Port

One dedicated IPMI LAN port is located on the rear I/O panel. This port accepts an RJ45 type cable.

3. Universal Serial Bus (USB) Ports

There are two USB 3.0 ports on the rear I/O panel. These support the type A connector.

4. COM Port

One serial communications (COM) port is included on the rear I/O panel.

5. UID Switch & UID LED

A Unit Identifier (UID SW) switch and UID LED (LED8) are located on the I/O backpanel. The rear UID LED (LED8) is located next to the UID switch. When you press the UID switch, both rear and front UID LED indicators will turn on. Press the UID switch again to turn off the LED indicators. The UID Indicator provides easy identification of a system that may be in need of service. See 2.6 for the front panel UID LED header location on JF1.

Note: UID can also be triggered via IPMI on the serverboard. For more information on IPMI, please refer to the IPMI User's Guide posted on our website at <http://www.supermicro.com>

4.4 Jumpers

Explanation of Jumpers

To modify the operation of the motherboard, jumpers are used to choose between optional settings. Jumpers create shorts between two pins to change the function associated with it. Pin 1 is identified with a square solder pad on the printed circuit board. See the motherboard layout page for jumper locations.

Note: On a two-pin jumper, "Closed" means the jumper is on both pins and "Open" indicates the jumper is either on only one pin or has been completely removed.

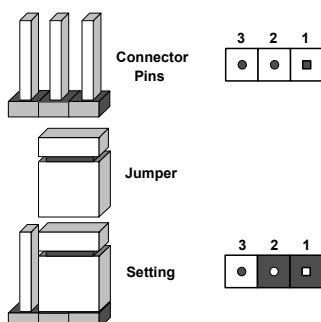

JSATA1

This 3-pin power connector at JSATA1 provides power from the motherboard to internal SATA hard drive or SSD device. Refer to the table below for pin definitions.

JSATA1 Pin Definitions	
Pin#	Definition
1-2	Auto (Default)
2-3	Force SATA

4.5 LED Indicators

Dedicated IPMI LAN port

A dedicated IPMI LAN is located on the rear I/O panel and has two LED indicators. The LED on the right indicates connection and activity, while the LED on the left indicates the speed of connection. The Link LED may amber, green, or off to indicate the speed of the connection. Refer to the tables below for more information.

Link LED, Connection Link Speed Indicator	
LED Color	Definition
Amber	1 Gb/s
Green	100 Mb/s
Off	10 Mb/s

Activity LED		
Color	State	Definition
None	No Connection	
Yellow	Solid On	Link
Yellow	Flashing	Active

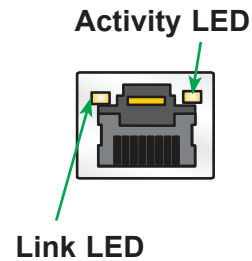

UID LED Indicator (LED8)

The rear LED8 is located next to the UID switch. The front UID LED is located on the front panel. When you press the UID switch, both rear LED8 and front UID LED indicators will turn on. Press the UID switch again to turn off the LED indicators. Use this UID Indicator to 'mark' the system, so the system can be easily identified whether on the front or back (e.g., a system rack with multiple units installed).

UID LED Indicator		
Color	State	Definition
None	Off	UID Off
Blue	Solid On	Unit Identified by Local Site
Blue	Slow Blinking	Unit Identified by Remote Site
Blue	Slow Blinking	System Recovery

BMC Heartbeat LED (LED1)

A BMC Heartbeat LED is located at LED1 on the motherboard. When LED1 is blinking, the BMC is functioning normally. See the table below for more information.

BMC Heartbeat LED State		
Color	State	Definition
Green	Solid On	BMC is not ready
Green	Blinking	BMC Normal
Green	Fast Blinking	BMC: Initializing

Onboard Power OK LED (LED7)

LED7 is an onboard power OK LED. When this LED7 is lit, it means the system is turned on, and all the system power rails are ready. When the system is turned off, or any one of the system power rails fail, this LED will turn off. Turn off the system, and unplug the power cable before removing or installing any component(s).

Onboard Power LED Indicator		
LED Color	State	Definition
None	Off	System Off
Green	Solid On	System On
Green	Blinking	System Recovery

Chapter 5

Software

After the hardware has been installed, you can install the Operating System (OS), configure RAID settings and install the drivers.

5.1 Microsoft Windows OS Installation

If you will be using RAID, you must configure RAID settings before installing the Windows OS and the RAID driver. Refer to the RAID Configuration User Guides posted on our website at www.supermicro.com/support/manuals.

Installing the OS

1. Create a method to access the Microsoft Windows installation ISO file. That can be a USB flash or media drive.
2. Boot from a bootable device with Windows OS installation. You can see a bootable device list by pressing **F11** during the system startup.

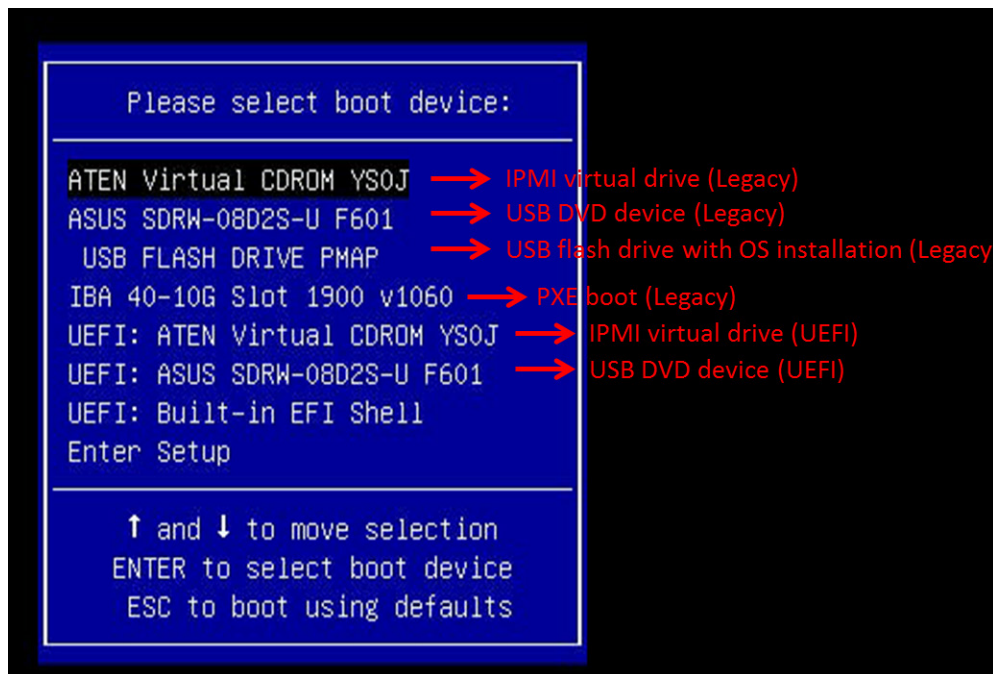

Figure 5-1. Select Boot Device

3. During Windows Setup, continue to the dialog where you select the drives on which to install Windows. If the disk you want to use is not listed, click on “Load driver” link at the bottom left corner.

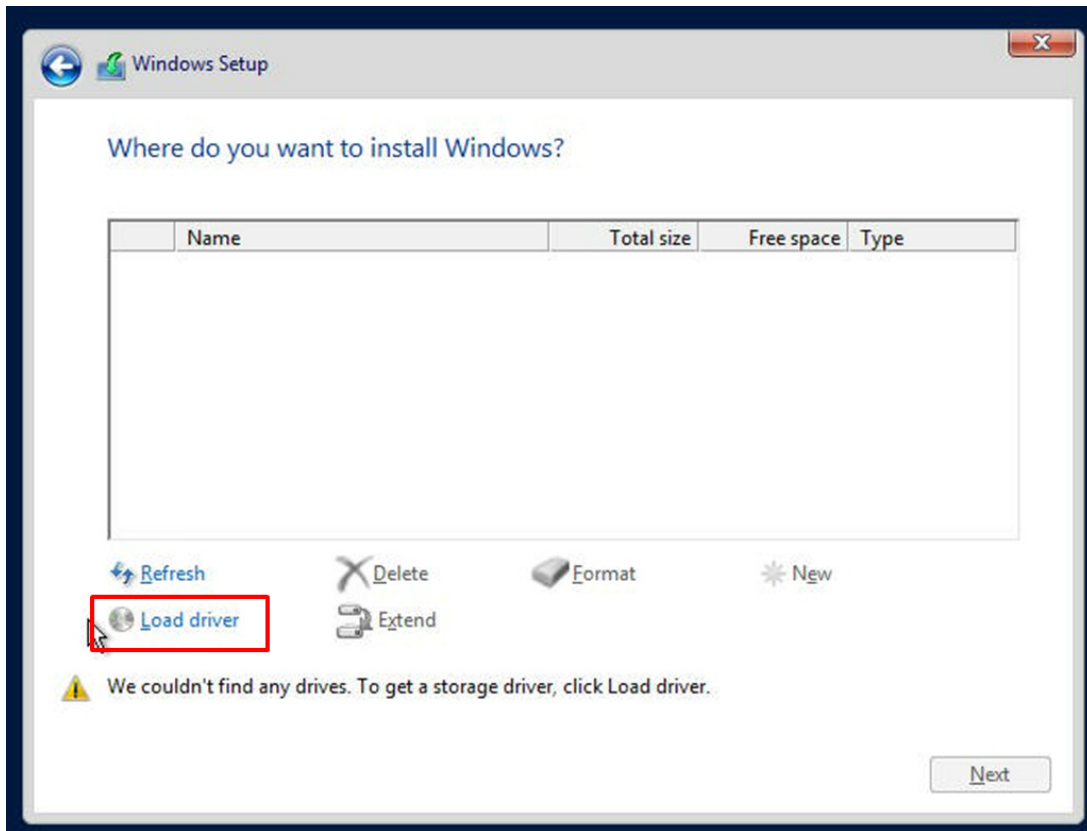

Figure 5-2. Load Driver Link

To load the driver, browse the USB flash drive for the proper driver files.

- For RAID, choose the SATA/sSATA RAID driver indicated then choose the storage drive on which you want to install it.
 - For non-RAID, choose the SATA/sSATA AHCI driver indicated then choose the storage drive on which you want to install it.
4. Once all devices are specified, continue with the installation.
 5. After the Windows OS installation has completed, the system will automatically reboot multiple times.

5.2 Driver Installation

The Supermicro website contains drivers and utilities for your system at <https://www.supermicro.com/wdl/driver>. Some of these must be installed, such as the chipset driver.

After accessing the website, go into the CDR_Images (in the parent directory of the above link) and locate the ISO file for your motherboard. Download this file to to a USB flash drive or a DVD. (You may also use a utility to extract the ISO file if preferred.)

Another option is to go to the Supermicro website at www.supermicro.com/products/. Find the product page for your motherboard, and "Download the Latest Drivers and Utilities".

Insert the flash drive or disk and the screenshot shown below should appear.

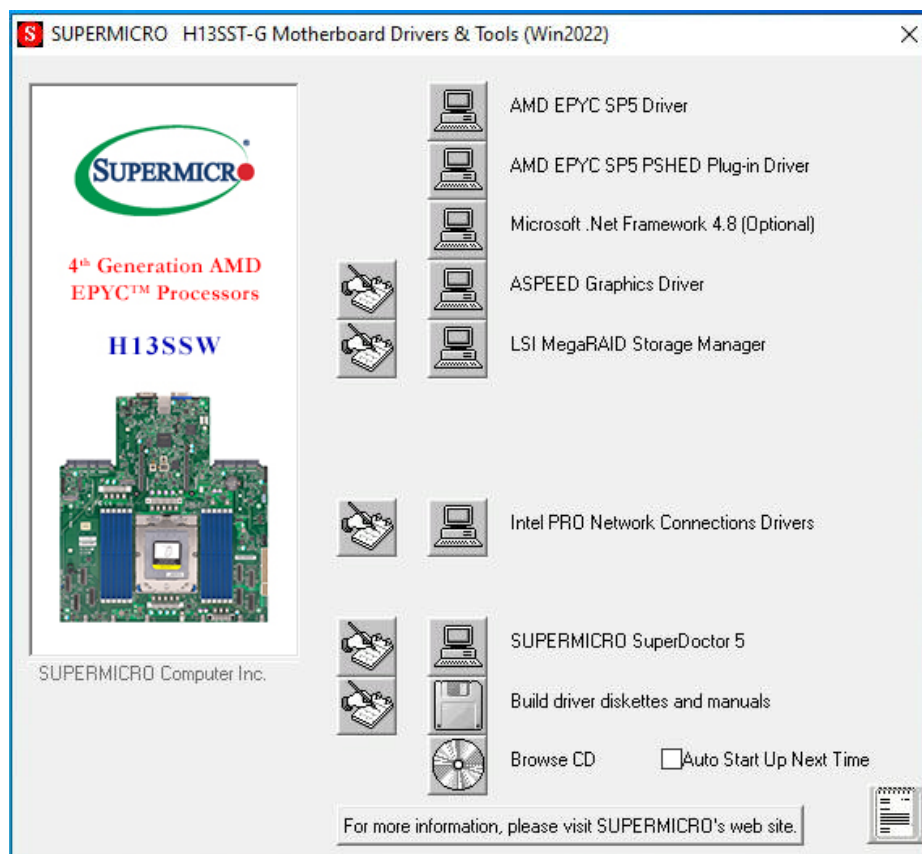

Figure 5-3. Driver & Tool Installation Screen

Note: Click the icons showing a hand writing on paper to view the readme files for each item. Click the computer icons to the right of these items to install each item (from top to the bottom) one at a time. **After installing each item, you must re-boot the system before moving on to the next item on the list.** The bottom icon with a CD on it allows you to view the entire contents.

5.3 SuperDoctor® 5

The Supermicro SuperDoctor 5 is a program that functions in a command-line or web-based interface for Windows and Linux operating systems. The program monitors such system health information as CPU temperature, system voltages, system power consumption, fan speed, and provides alerts via email or Simple Network Management Protocol (SNMP).

SuperDoctor 5 comes in local and remote management versions and can be used with Nagios to maximize your system monitoring needs. With SuperDoctor 5 Management Server (SSM Server), you can remotely control power on/off and reset chassis intrusion for multiple systems with SuperDoctor 5 or IPMI. SuperDoctor 5 Management Server monitors HTTP, FTP, and SMTP services to optimize the efficiency of your operation.

[SuperDoctor® Manual and Resources](#)



Figure 5-4. SuperDoctor 5 Interface Display Screen (Health Information)

5.4 IPMI

The H13SSW supports the Intelligent Platform Management Interface (IPMI). IPMI is used to provide remote access, monitoring and management. There are several BIOS settings that are related to IPMI.

Supermicro ships standard products with a unique password for the BMC ADMIN user. This password can be found on a label on the motherboard.

For general documentation and information on IPMI, please visit our website at: <http://www.supermicro.com/products/nfo/IPMI.cfm>.

Chapter 6

Optional Components

This chapter describes optional system components and installation procedures.

Optional Parts
Storage Control Card
High RPM fans for high TDP CPU and GPU support
GPU Support
Cable Management Arm
TPM security module

6.1 Storage Control Cards

Supermicro offers controller cards for some storage options.

Storage Protocols Supported

The storage drive bays can support SATA or SAS.

SATA – The default configuration supports SATA drives.

SAS – An add-on controller card can support up to SAS (or SATA) drives. Additional cables are required.

6.2 Upgrade Fans

Superior cooling can be provided by an optional upgrade to FAN-0206L4. See [Section 3.7](#) for installation instructions.

6.3 GPU Support

Only single-width, half-length GPUs are supported. Installation is the same as PCIe expansion cards.

GPU Support	
Quantity	Two double-width, full-length, full-height
Power Cable	Optional
Thermal Kit	Upgraded fans: three FAN-0206L4
Conditions	Supports up to 400W TDP CPU

6.4 Cable Management Arm

The system supports a cable management arm (CMA), which keeps the rear cables organized and clear of the rail mechanisms when the system is extended out the front of the rack for maintenance.

The CMA attaches to the rack mounting rails by means of four connectors. They are labeled on the connectors 1, 2, 3, and 4.

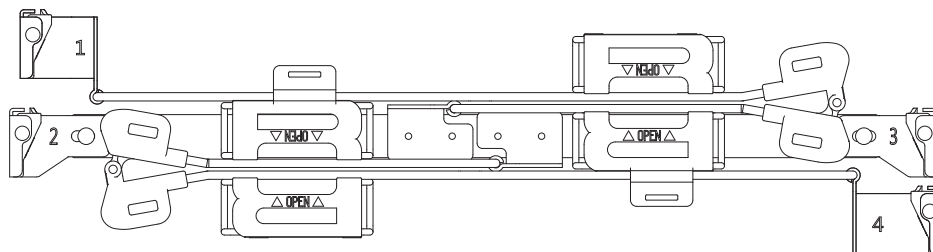

Figure 6-1. Cable Management Arm

Cable Arm Details		
Optional Part	Part Number	Description
Cable Arm Adapter	MCP-120-82601-0N	Cable Arm Adapter for 2U
Cable Arm	MCP-290-00073-0N	Supermicro Cable Management Arm for 2U, 3U and 4U chassis

Installing the Cable Management Arm

1. Slide CMA connector #1 forward onto the two posts on the rear of the right *inner* rail (right side when viewed from the front). It snaps into place.
2. Slide CMA connector #2 forward onto the two posts on the rear of the right *middle* rail. It snaps into place.

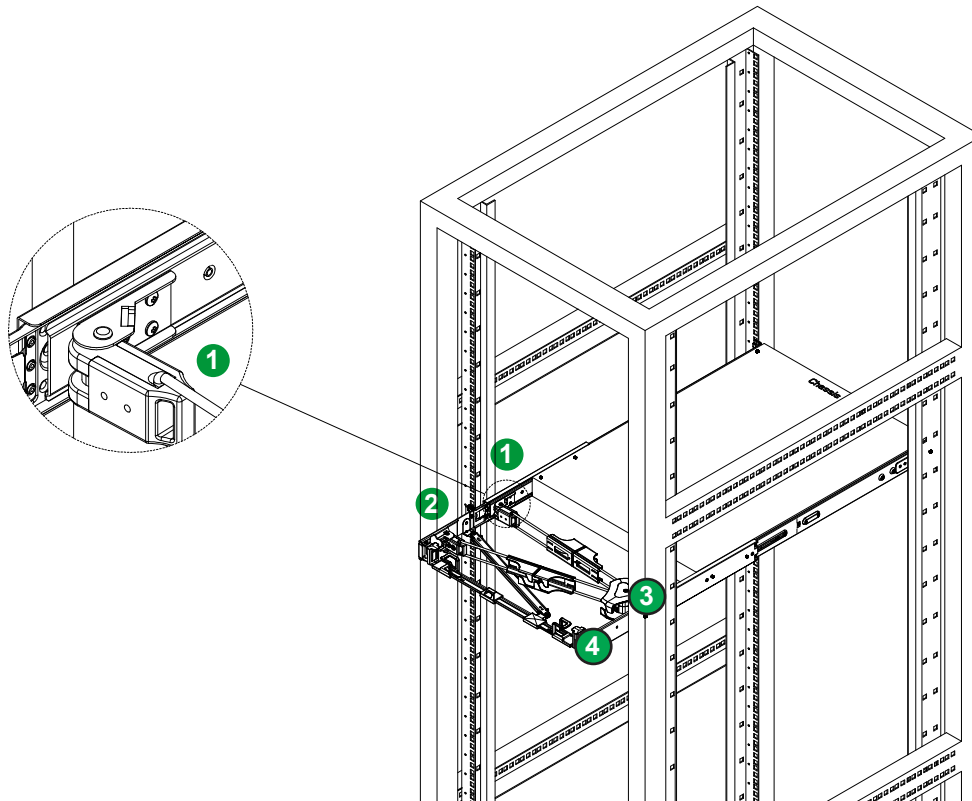

Figure 6-2. Installing the Connectors

3. Slide CMA connector #3 forward onto the two posts on the rear of the left middle rail. It snaps into place.
4. For CMA connector #4, align the metal tabs with the slots on the rear of the left outer rail and push it forward. It snaps into place.
5. Route the cables through the holding brackets, leaving enough slack.

Removing the Cable Management Arm

1. Remove cables from the CMA,
2. For CMA connector #4, pull the metal release tab toward the center of the rack and slide the connector toward the rear to release it.
3. For CMA connectors #3, #2, and #1, depress the front edge of the yellow plastic rocker lock, and slide the connector toward the rear to release it.

6.5 TPM Security Module

SPI capable TPM 2.0 (or 1.2) with Infineon 9670 controller, horizontal form factor

The JTPM1 header is used to connect a Trusted Platform Module (TPM). A TPM is a security device that supports encryption and authentication in hard drives. It enables the motherboard to deny access if the TPM associated with the hard drive is not installed in the system.

Details and installation procedures are at:

<http://www.supermicro.com/manuals/other/TPM.pdf>.

- AOM-TPM-9670V

Chapter 7

Troubleshooting and Support

7.1 Information Resources

Website

A great deal of information is available on the Supermicro website, supermicro.com.

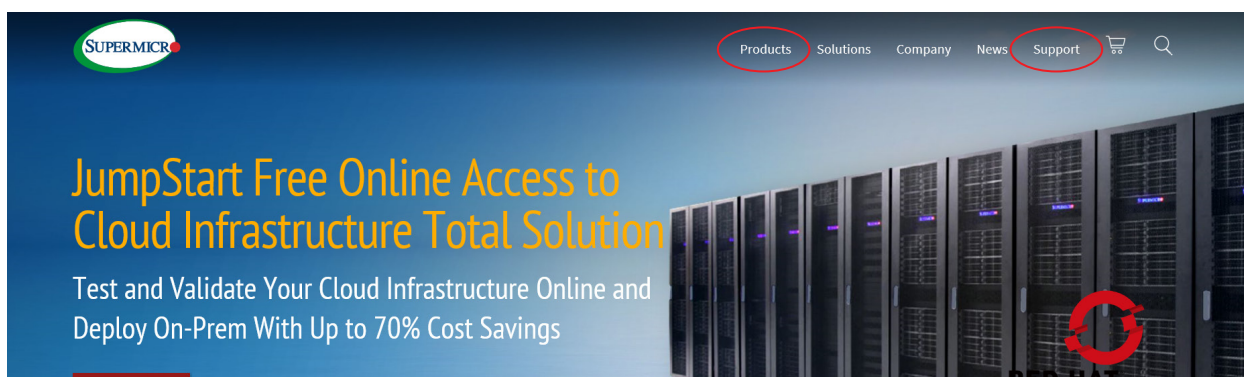

Figure 7-1. Supermicro Website

- Specifications for servers and other hardware are available by clicking the **Products** option.
- The **Support** option offers downloads (manuals, BIOS/BMC, drivers, etc.), FAQs, RMA, warranty, and other service extensions.

Direct Links for the AS-2015CS-TNR System

[AS-2015CS-TNR specifications page](#)

H13SSW [motherboard page](#) for links to the Quick Reference Guide, User Manual, validated storage drives, etc.

Direct Links for General Support and Information

[Frequently Asked Questions](#)

[Add-on card descriptions](#)

[TPM User Guide](#)

General Memory Configuration Guide: [H13](#)

[BMC User Guide](#)

[SuperDoctor5 Large Deployment Guide](#)

Direct Links (continued)

[Product Matrices](#) page for links to tables summarizing specs for systems, motherboards, power supplies, riser cards, add-on cards, etc.

[Security Center](#) for recent security notices

[Supermicro Phone and Addresses](#)

7.2 Intelligent Platform Management Interface (IPMI)

The system supports the Intelligent Platform Management Interface (IPMI). IPMI is used to provide remote access, monitoring, and management. There are several BIOS settings that are related to IPMI.

For general documentation and information on IPMI, please visit our website at: https://www.supermicro.com/manuals/other/BMC_IPMI_X13_H13.pdf.

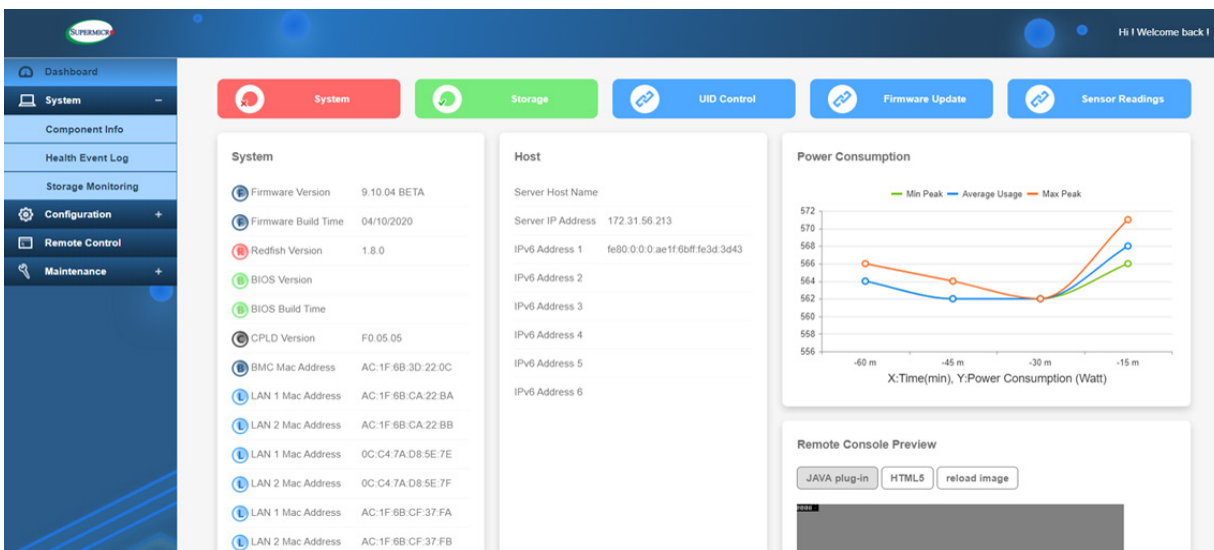

Figure 7-2. IPMI Sample

7.3 Troubleshooting Procedures

Use the following procedures to troubleshoot your system. If you have followed all of the procedures below and still need assistance, refer to the [Technical Support Procedures](#) or [Returning Merchandise for Service](#) section(s) in this chapter. [Power down](#) the system before changing any non hot-swap hardware components.

Before Power On

1. Check that the BMC Heartbeat (LED1) is blinking before the motherboard is turned on.
2. Check that the Onboard Power OK (LED7) on the motherboard is on.
3. Make sure that the power connector is connected to your power supply.
4. Make sure that no short circuits exist between the motherboard and chassis.
5. Disconnect all cables from the motherboard, including those for the keyboard and mouse.
6. Remove all add-on cards.
7. Install a CPU, a heatsink*, and at least one DIMM on the motherboard. Check all jumper settings properly. *Make sure that the heatsink is fully seated.
8. Use the correct type of onboard CMOS battery (CR2032) as recommended by the manufacturer. To avoid possible explosion, do not install the CMOS battery upside down.

No Power

1. Make sure that no short circuits exist between the motherboard and the chassis.
2. Verify that all jumpers are set to their default positions.
3. Check that the 115V/230V switch on the power supply is properly set.
4. Turn the power switch on and off to test the system
5. The CMOS battery on your motherboard may be old. Check to verify that it still supplies approximately 3VDC. If it does not, replace it with a new one.

No Video

1. Check that the VGA cable is connected properly, and the monitor is on.
2. Check if you follow the guidelines to install the memory module (see DIMM Module Population in Chapter 2).

3. Reseat the memory DIMM modules.

Note: If you are a system integrator, VAR or OEM, a POST diagnostics card is recommended.

System Boot Failure

If the system does not display POST (Power-On-Self-Test) or does not respond after the power is turned on, check the following:

1. Clear the CMOS settings by unplugging the power cord and contacting both pads on the CMOS Clear Jumper (JBT1). Refer to [chapter 4](#).
2. Remove all components from the motherboard, especially the DIMM modules.
3. Turn on the system with only one DIMM module installed. If the system boots, check for bad DIMM modules or slots by following the Memory Errors Troubleshooting procedure in this Chapter.

Memory Errors

1. Make sure that the DIMM modules are properly and fully installed.
2. Confirm that you are using the correct memory. It is recommended that you use the same memory type and speed for all DIMMs in the system. See Section 3.4 for memory details.
3. Check for bad DIMM modules or slots by swapping modules between slots and noting the results.
4. Check the power supply voltage 115V/230V switch.

The System Cannot Retain the Setup Configuration

1. Make sure that you are using a high quality power supply. A poor quality power supply may cause the system to lose the CMOS setup information. Refer to [_](#) for details on power supplies.
2. The battery on your motherboard may be old. Check to verify that it still supplies approximately 3VDC. If it does not, replace it with a new one.
3. If the above steps do not fix the setup configuration problem, contact your vendor for repairs.

If the System Becomes Unstable

A. If the system becomes unstable during or after OS installation, check the following:

1. CPU/BIOS support: Make sure that your CPU is supported and that you have the latest BIOS installed in your system.

2. Memory support: Make sure that the memory modules are supported by testing the modules using memtest86 or a similar utility.

Note: Refer to the product page on our website at <http://www.supermicro.com> for memory and CPU support and updates.

3. HDD support: Make sure that all hard disk drives (HDDs) work properly. Replace the bad HDDs with good ones.
4. System cooling: Check the system cooling to make sure that all heatsink fans and CPU/system fans, etc., work properly. Check the hardware monitoring settings in the IPMI to make sure that the CPU and system temperatures are within the normal range. Also check the front panel Overheat LED and make sure that it is not on.
5. Adequate power supply: Make sure that the power supply provides adequate power to the system. Make sure that all power connectors are connected. Please refer to our website for more information on the minimum power requirements.
6. Proper software support: Make sure that the correct drivers are used.

B. If the system becomes unstable before or during OS installation, check the following:

1. Source of installation: Make sure that the devices used for installation are working properly, including boot devices such as USB flash or media drives.
2. Cable connection: Check to make sure that all cables are connected and working properly.
3. Using the minimum configuration for troubleshooting: Remove all unnecessary components (starting with add-on cards first), and use the minimum configuration (but with a CPU and a memory module installed) to identify the trouble areas. Refer to the steps listed in Section A above for proper troubleshooting procedures.
4. Identifying bad components by isolating them: If necessary, remove a component in question from the chassis, and test it in isolation to make sure that it works properly. Replace a bad component with a good one.
5. Check and change one component at a time instead of changing several items at the same time. This will help isolate and identify the problem.
6. To find out if a component is good, swap this component with a new one to see if the system will work properly. If so, then the old component is bad. You can also install the component in question in another system. If the new system works, the component is good and the old system has problems.

7.4 Crash Dump Using BMC

In the event of a processor internal error (IERR) that crashes your system, you may want to provide information to support staff. You can download a crash dump of status information using BMC. The BMC manual is available at <https://www.supermicro.com/en/solutions/management-software/bmc-resources>.

Check BMC Error Log

1. Access the BMC web interface.

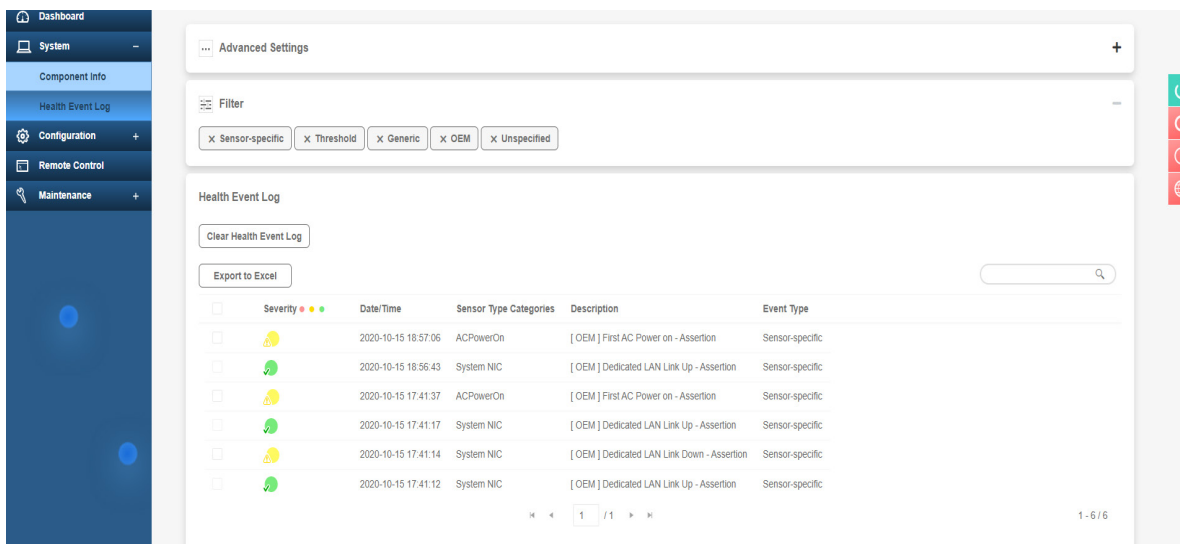

Figure 7-4. BMC Event Log

2. Click the **Server Health** tab, then **Event Log** to verify an IERR error.

In the event of an IERR, the BMC executes a crash dump. You must download the crash dump and save it.

7.5 UEFI BIOS Recovery

Important: Do not upgrade the BIOS unless your system has a BIOS-related issue. Flashing the wrong BIOS can cause irreparable damage to the system. In no event shall Supermicro be liable for direct, indirect, special, incidental, or consequential damages arising from a BIOS update. If you do update the BIOS, do not shut down or reset the system while the BIOS is updating to avoid possible boot failure.

Overview

The Unified Extensible Firmware Interface (UEFI) provides a software-based interface between the operating system and the platform firmware in the pre-boot environment. The UEFI specification supports an architecture-independent mechanism that will allow the UEFI OS loader stored in an add-on card to boot the system. The UEFI offers clean, hands-off management to a computer during system boot.

Recovering the UEFI BIOS Image

A UEFI BIOS flash chip consists of a recovery BIOS block and a main BIOS block (a main BIOS image). The recovery block contains critical BIOS codes, including memory detection and recovery codes for the user to flash a healthy BIOS image if the original main BIOS image is corrupted. When the system power is turned on, the recovery block codes execute first. Once this process is complete, the main BIOS code will continue with system initialization and the remaining POST (Power-On Self-Test) routines.

Note 1: Follow the BIOS recovery instructions below for BIOS recovery when the main BIOS block crashes.

Note 2: When the BIOS recovery block crashes, you will need to follow the procedures to make a Returned Merchandise Authorization (RMA) request. Also, you may use the Supermicro Update Manager (SUM) Out-of-Band (https://www.supermicro.com.tw/products/nfo/SMS_SUM.cfm) to reflash the BIOS.

Recovering the Main BIOS Block with a USB Device

This feature allows the user to recover the main BIOS image using a USB-attached device without additional utilities used. A USB flash device such as a USB Flash Drive, or a USB CD/DVD ROM/RW device can be used for this purpose. However, a USB Hard Disk drive cannot be used for BIOS recovery at this time.

The file system supported by the recovery block is FAT (including FAT12, FAT16, and FAT32) which is installed on a bootable or non-bootable USB-attached device. However, the BIOS might need several minutes to locate the SUPER.ROM file if the media size becomes too large due to the huge volumes of folders and files stored in the device.

To perform UEFI BIOS recovery using a USB-attached device, follow the instructions below.

1. Using a different machine, copy the "Super.ROM" binary image file into the Root "\\" directory of a USB device or a writable CD/DVD.

Note 1: If you cannot locate the "Super.ROM" file in your drive disk, visit our website at www.supermicro.com to download the BIOS package. Extract the BIOS binary image into a USB flash device and rename it "Super.ROM" for the BIOS recovery use.

Note 2: Before recovering the main BIOS image, confirm that the "Super.ROM" binary image file you download is the same version or a close version meant for your motherboard.

2. Insert the USB device that contains the new BIOS image ("Super.ROM") into your USB drive and reset the system when the following screen appears.
3. After locating the healthy BIOS binary image, the system will enter the BIOS Recovery menu as shown below.



Note: At this point, you may decide if you want to start the BIOS recovery. If you decide to proceed with BIOS recovery, follow the procedures below.

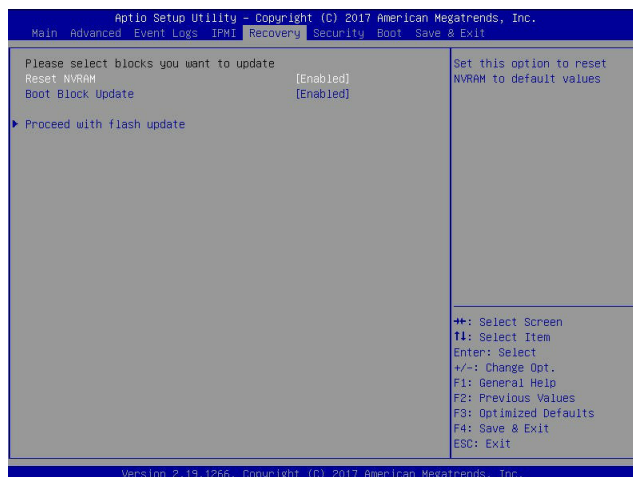

4. When the screen as shown above displays, use the arrow keys to select the item "Proceed with flash update" and press the <Enter> key. You will see the BIOS recovery progress as shown in the screen below.

Note: Do not interrupt the BIOS flashing process until it has completed.

5. After the BIOS recovery process is complete, press any key to reboot the system.

6. Using a different system, extract the BIOS package into a USB flash drive.

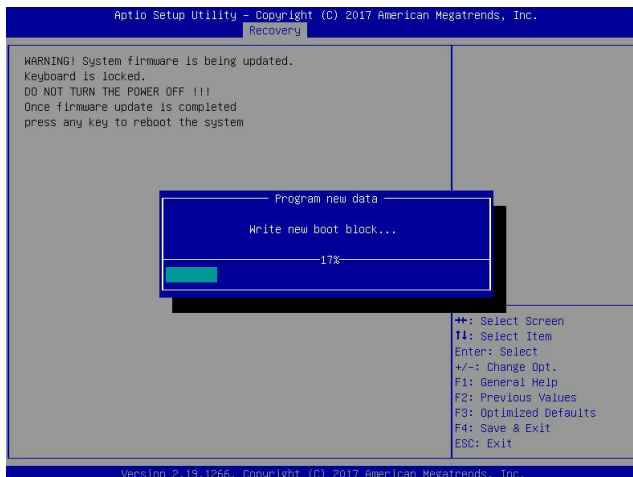

7. Press continuously during system boot to enter the BIOS Setup utility. From the top of the tool bar, select Boot to enter the submenu. From the submenu list, select Boot Option

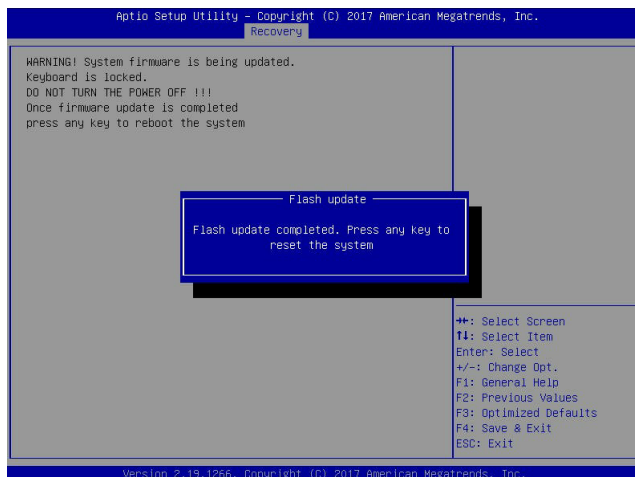

#1 as shown below. Then, set Boot Option #1 to [UEFI AP:UEFI: Built-in EFI Shell]. Press <F4> to save the settings and exit the BIOS Setup utility.

1. When the UEFI Shell prompt appears, type `fs#` to change the device directory path. Go to the directory that contains the BIOS package you extracted earlier from Step 6. Enter `flash.nsh BIOSname.###` at the prompt to start the BIOS update process.

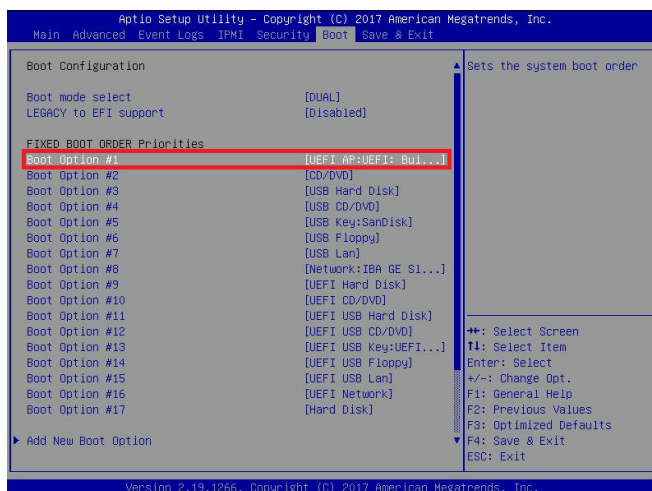

Note: Do not interrupt this process until the BIOS flashing is complete.

```

UEFI Interactive Shell v2.1
EDK II
UEFI v2.50 (American Megatrends, 0x0005000C)
Mapping table
  FS0: Alias(s):HD0:0:0:BLK1:
        PciRoot(0x0)/Pci(0x14,0x0)/USB(0x11,0x0)/HD(1,MBR,0x37901D72,0x800,0x1
CR9592)
  BLK0: Alias(s):
        PciRoot(0x0)/Pci(0x14,0x0)/USB(0x11,0x0)
Press F8 in 1 seconds to skip startup.nsh or any other key to continue.
Shell: fs0:
FS0:\> cd \AFUDOS
FS0:\AFUDOS> cd SNIJPM2_03162017
FS0:\AFUDOS\SNIJPM2_03162017> flash.nsh X110PU7_314

```

1. The screen above indicates that the BIOS update process is complete. When you see the screen above, unplug the AC power cable from the power supply, clear CMOS, and plug

```

Done.
[ Access Cmos Port Ex ]
<Read>
Index 0x51: 0x10

Done.
*****
* Program BIOS and ME (including FDT) regions...
*****
| AMT Firmware Update Utility v5.09.01.1917 |
| Copyright (C)2017 American Megatrends Inc. All Rights Reserved. |
-----
CPUID = 50652

Reading flash ..... done
- ME Data Size checking - ok
- FFS checksums ..... ok
- Check RomLayout ..... Ok
Erasing Boot Block ..... done
Updating Boot Block ..... done
Verifying Boot Block ..... done
_Erasing Main Block ..... 0x00132000 (0x)

```

the AC power cable in the power supply again to power on the system.

2. Press continuously to enter the BIOS Setup utility.

```

Verifying NDB Block ..... done
- Update success for FDR
+ Update success for IE
- Successful Update Recovery Loader to OPRx!!
- Successful Update MFSB!!
- Successful Update FPR!!
- Successful Update MFS, IVBI and IVB2!!
- Successful Update FLOG and UTDK!!
- ME Entire Image update success !!
WARNING : System must power-off to have the changes take effect!
Moving FS0:\AFUDOS\SNIJPM2_03162017\Fdtv64.efi -> FS0:\AFUDOS\SNIJPM2_03162017\
d1.smc
- [ok]
Moving FS0:\AFUDOS\SNIJPM2_03162017\Fuef1x64.efi -> FS0:\AFUDOS\SNIJPM2_0316201
7\Fuef1.smc
- [ok]
*****
* Please ignore this 'Shell: Cannot read from file - Device Error'
* warning message due to it does not impact flashing process.
*****
Deleting "FS0:\AFUDOS\SNIJPM2_03162017\Fuef1.smc"
Delete successful.
FS0:\>

```

3. Press <F3> to load the default settings.
4. After loading the default settings, press <F4> to save the settings and exit the BIOS Setup utility.

7.6 CMOS Clear

JBT1 is used to clear CMOS, which will also clear any passwords. Instead of pins, this jumper consists of contact pads to prevent accidentally clearing the contents of CMOS.

To Clear CMOS

1. First [power down](#) the system completely.
2. [Remove the top cover](#) to access the motherboard.
3. [Remove the onboard battery](#) from the motherboard.
4. Short the CMOS pads with a metal object such as a small screwdriver for at least four seconds.
5. Remove the screwdriver or shorting device.
6. Re-install the motherboard battery.
7. Replace the cover, reconnect the power cords and power on the system.

Notes: Clearing CMOS will also clear all passwords.

Do not use the PW_ON connector to clear CMOS.



JBT1 contact pads

7.7 Where to Get Replacement Components

If you need replacement parts for your system, to ensure the highest level of professional service and technical support, purchase exclusively from our Supermicro Authorized Distributors/System Integrators/Resellers. A list can be found at: <http://www.supermicro.com>. Click the "Where to Buy" tab.

7.8 Reporting an Issue

Technical Support Procedures

Before contacting Technical Support, please take the following steps. If your system was purchased through a distributor or reseller, please contact them for troubleshooting services. They have the best knowledge of your specific system configuration.

1. Please review the [Troubleshooting Procedures](#) in this manual and [Frequently Asked Questions](#) on our website before contacting Technical Support.
2. BIOS upgrades can be downloaded from our website. **Note:** Not all BIOS can be flashed depending on the modifications to the boot block code.
3. If you still cannot resolve the problem, include the following information when contacting us for technical support:
 - System, motherboard, and chassis model numbers and PCB revision number
 - BIOS release date/version (this can be seen on the initial display when your system first boots up)
 - System configuration

An example of a Technical Support form is posted on our [website](#). Distributors: For immediate assistance, please have your account number ready when contacting our technical support department by email.

Returning Merchandise for Service

A receipt or copy of your invoice marked with the date of purchase is required before any warranty service will be rendered. You can obtain service by calling your vendor for a Returned Merchandise Authorization (RMA) number. When returning to the manufacturer, the RMA number should be prominently displayed on the outside of the shipping carton, and mailed prepaid or hand-carried. Shipping and handling charges will be applied for all orders that must be mailed when service is complete.

For faster service, RMA authorizations may be requested online (<http://www.supermicro.com/support/rma/>).

Whenever possible, repack the chassis in the original Supermicro carton, using the original packaging material. If these are no longer available, be sure to pack the chassis securely, using packaging material to surround the chassis so that it does not shift within the carton and become damaged during shipping.

This warranty only covers normal consumer use and does not cover damages incurred in shipping or from failure due to the alteration, misuse, abuse or improper maintenance of products.

During the warranty period, contact your distributor first for any product problems.

Vendor Support Filing System

For issues related to Intel, use the Intel IPS filing system:

<https://www.intel.com/content/www/us/en/design/support/ips/training/welcome.html>

For issues related to Red Hat Enterprise Linux, since it is a subscription based OS, contact your account representative.

7.9 Feedback

Supermicro values your feedback as we strive to improve our customer experience in all facets of our business. Please email us at techwriterteam@supermicro.com to provide feedback on our manuals.

Appendix A

Standardized Warning Statements for AC Systems

About Standardized Warning Statements

The following statements are industry standard warnings, provided to warn the user of situations which have the potential for bodily injury. Should you have questions or experience difficulty, contact Supermicro's Technical Support department for assistance. Only certified technicians should attempt to install or configure components.

Read this appendix in its entirety before installing or configuring components in the Supermicro chassis.

These warnings may also be found on our website at http://www.supermicro.com/about/policies/safety_information.cfm.

Warning Definition



Warning! This warning symbol means danger. You are in a situation that could cause bodily injury. Before you work on any equipment, be aware of the hazards involved with electrical circuitry and be familiar with standard practices for preventing accidents.

警告の定義

この警告サインは危険を意味します。

人身事故につながる可能性がありますので、いずれの機器でも動作させる前に、電気回路に含まれる危険性に注意して、標準的な事故防止策に精通して下さい。

此警告符号代表危險。

您正处于可能受到严重伤害的工作环境中。在您使用设备开始工作之前，必须充分意识到触电的危险，并熟练掌握防止事故发生的标准工作程序。请根据每项警告结尾的声明号码找到此设备的安全性警告说明的翻译文本。

此警告符號代表危險。

您正處於可能身體可能會受損傷的工作環境中。在您使用任何設備之前，請注意觸電的危險，並且要熟悉預防事故發生的標準工作程序。請依照每一注意事項後的號碼找到相關的翻譯說明內容。

Warnung

WICHTIGE SICHERHEITSHINWEISE

Dieses Warnsymbol bedeutet Gefahr. Sie befinden sich in einer Situation, die zu Verletzungen führen kann. Machen Sie sich vor der Arbeit mit Geräten mit den Gefahren elektrischer Schaltungen und den üblichen Verfahren zur Vorbeugung vor Unfällen vertraut. Suchen Sie mit der am Ende jeder Warnung angegebenen Anweisungsnummer nach der jeweiligen Übersetzung in den übersetzten Sicherheitshinweisen, die zusammen mit diesem Gerät ausgeliefert wurden.

BEWAHREN SIE DIESE HINWEISE GUT AUF.

INSTRUCCIONES IMPORTANTES DE SEGURIDAD

Este símbolo de aviso indica peligro. Existe riesgo para su integridad física. Antes de manipular cualquier equipo, considere los riesgos de la corriente eléctrica y familiarícese con los procedimientos estándar de prevención de accidentes. Al final de cada advertencia encontrará el número que le ayudará a encontrar el texto traducido en el apartado de traducciones que acompaña a este dispositivo.

GUARDE ESTAS INSTRUCCIONES.

IMPORTANTES INFORMATIONS DE SÉCURITÉ

Ce symbole d'avertissement indique un danger. Vous vous trouvez dans une situation pouvant entraîner des blessures ou des dommages corporels. Avant de travailler sur un équipement, soyez conscient des dangers liés aux circuits électriques et familiarisez-vous avec les procédures couramment utilisées pour éviter les accidents. Pour prendre connaissance des traductions des avertissements figurant dans les consignes de sécurité traduites qui accompagnent cet appareil, référez-vous au numéro de l'instruction situé à la fin de chaque avertissement.

CONSERVEZ CES INFORMATIONS.

תקנון הזהרות אזהרה

הזהרות הבאות הן אזהרות על פי תקני התעשייה, על מנת להזהיר את המשתמש מפני חבלה פיזית אפשרית. במידה ויש שאלות או היתקלות בבעיה כלשהי, יש ליצור קשר עם מחלקת תמיכה טכנית של סופרמיקרו. טכנאים מוסמכים בלבד רשאים להתקין או להגדיר את הרכיבים. יש לקרוא את הנספח במלואו לפני התקנת או הגדרת הרכיבים במארזי סופרמיקרו.

اَكْ ف حالة وُكي اَي تتسبب ف اصابة جسدهُ هذا الزهز عُ خطر! تحذُرُ .
 قبل اَي تعول على اَي هعدات، كي على علن بالوخاطز ال اُجوة عي الذوائر
 الكهزبائِة
 وكي على دراةُ بالووارسات النقاىِة لو عُ وقع اَي حادث
 استخدم رقن الب اى الو صُص ف هاةُ كل تحذُرُ للعشر تزجوتها

안전을 위한 주의사항

경고!

이 경고 기호는 위험이 있음을 알려 줍니다. 작업자의 신체에 부상을 야기 할 수 있는 상태에 있게 됩니다. 모든 장비에 대한 작업을 수행하기 전에 전기회로와 관련된 위험요소들을 확인하시고 사전에 사고를 방지할 수 있도록 표준 작업절차를 준수해 주시기 바랍니다.

해당 번역문을 찾기 위해 각 경고의 마지막 부분에 제공된 경고문 번호를 참조하십시오

BELANGRIJKE VEILIGHEIDSINSTRUCTIES

Dit waarschuwings symbool betekent gevaar. U verkeert in een situatie die lichamelijk letsel kan veroorzaken. Voordat u aan enige apparatuur gaat werken, dient u zich bewust te zijn van de bij een elektrische installatie betrokken risico's en dient u op de hoogte te zijn van de standaard procedures om ongelukken te voorkomen. Gebruik de nummers aan het eind van elke waarschuwing om deze te herleiden naar de desbetreffende locatie.

BEWAAR DEZE INSTRUCTIES

Installation Instructions



Warning! Read the installation instructions before connecting the system to the power source.

設置手順書

システムを電源に接続する前に、設置手順書をお読み下さい。

警告

将此系统连接电源前,请先阅读安装说明。

警告

將系統與電源連接前，請先閱讀安裝說明。

Warnung

Vor dem Anschließen des Systems an die Stromquelle die Installationsanweisungen lesen.

¡Advertencia!

Lea las instrucciones de instalación antes de conectar el sistema a la red de alimentación.

Attention

Avant de brancher le système sur la source d'alimentation, consulter les directives d'installation.

יש לקרוא את הוראות התקנה לפני חיבור המערכת למקור מתח.

اقر إرشادات التركيب قبل توصيل النظام إلى مصدر للطاقة

시스템을 전원에 연결하기 전에 설치 안내를 읽어주십시오.

Waarschuwing

Raadpleeg de installatie-instructies voordat u het systeem op de voedingsbron aansluit.

Circuit Breaker

Warning! This product relies on the building's installation for short-circuit (overcurrent) protection. Ensure that the protective device is rated not greater than: 250 V, 20 A.

サーキット・ブレーカー

この製品は、短絡(過電流)保護装置がある建物での設置を前提としています。

保護装置の定格が250 V、20 Aを超えないことを確認下さい。

警告

此产品的短路(过载电流)保护由建筑物的供电系统提供,确保短路保护设备的额定电流不大于250 V,20 A。

警告

此產品的短路(過載電流)保護由建築物的供電系統提供,確保短路保護設備的額定電流不大於250 V,20 A。

Warnung

Dieses Produkt ist darauf angewiesen, dass im Gebäude ein Kurzschluss- bzw. Überstromschutz installiert ist. Stellen Sie sicher, dass der Nennwert der Schutzvorrichtung nicht mehr als: 250 V, 20 A beträgt.

¡Advertencia!

Este equipo utiliza el sistema de protección contra cortocircuitos (o sobrecorrientes) del edificio. Asegúrese de que el dispositivo de protección no sea superior a: 250 V, 20 A.

Attention

Pour ce qui est de la protection contre les courts-circuits (surtension), ce produit dépend de l'installation électrique du local. Vérifiez que le courant nominal du dispositif de protection n'est pas supérieur à :250 V, 20 A.

מוצר זה מסתמך על הגנה המותקנת במבנים למניעת קצר חשמלי. יש לוודא כי המכשיר המגן מפני הקצר החשמלי הוא לא יותר מ-250 VDC, 20 A

هذا المنتج يعتمد على معدات الحماية من الدوائر القصيرة التي تم تثبيتها في المبنى
تأكد من أن تقييم الجهاز الوقائي ليس أكثر من : 20 A, 250 V

경고!

이 제품은 전원의 단락(과전류)방지에 대해서 전적으로 건물의 관련 설비에 의존합니다. 보호장치의 정격이 반드시 250 V(볼트), 20 A(암페어)를 초과하지 않도록 해야 합니다.

Waarschuwing

Dit product is afhankelijk van de kortsluitbeveiliging (overspanning) van uw elektrische installatie. Controleer of het beveiligde apparaat niet groter gedimensioneerd is dan 250 V, 20 A.

Power Disconnection Warning



Warning! The system must be disconnected from all sources of power and the power cord removed from the power supply module(s) before accessing the chassis interior to install or remove system components (except for hot-swap components).



電源切断の警告

システムコンポーネントの取り付けまたは取り外しのために、シャーシ内部にアクセスするには、システムの電源はすべてのソースから切断され、電源コードは電源モジュールから取り外す必要があります。

警告

在你打开机箱并安装或移除内部器件前,必须将系统完全断电,并移除电源线。

警告

在您打開機殼安裝或移除內部元件前，必須將系統完全斷電，並移除電源線。

Warnung

Das System muss von allen Quellen der Energie und vom Netzanschlusskabel getrennt sein, das von den Spg.Versorgungsteilmodulen entfernt wird, bevor es auf den Chassisinnenraum zurückgreift, um Systemsbestandteile anzubringen oder zu entfernen.

¡Advertencia!

El sistema debe ser disconnected de todas las fuentes de energía y del cable eléctrico quitado de los módulos de fuente de alimentación antes de tener acceso el interior del chasis para instalar o para quitar componentes de sistema.

Attention

Le système doit être débranché de toutes les sources de puissance ainsi que de son cordon d'alimentation secteur avant d'accéder à l'intérieur du chassis pour installer ou enlever des composants de système.

אזהרה מפני ניתוק חשמלי

אזהרה!

יש לנתק את המערכת מכל מקורות החשמל ויש להסיר את כבל החשמלי מהספק לפני גישה לחלק הפנימי של המארז לצורך התקנת או הסרת רכיבים.

يجب فصل انظاؤ من جميع مصادر انطاقت وإزانت سهك انكهرباء من وحدة امداد انطاقت قيم

انصل إلى امناطق انداخييت نههيكم نشييج أو إزانت مكنناث الجهاز

경고!

시스템에 부품들을 장착하거나 제거하기 위해서는 새시 내부에 접근하기 전에 반드시 전원 공급장치로부터 연결되어있는 모든 전원과 전기코드를 분리해주어야 합니다.

Waarschuwing

Voordat u toegang neemt tot het binnenwerk van de behuizing voor het installeren of verwijderen van systeem onderdelen, dient u alle spanningsbronnen en alle stroomkabels aangesloten op de voeding(en) van de behuizing te verwijderen

Equipment Installation



Warning! Only authorized personnel and qualified service persons should be allowed to install, replace, or service this equipment.

機器の設置

トレーニングを受け認定された人だけがこの装置の設置、交換、またはサービスを許可されています。

警告

只有经过培训且具有资格的人员才能进行此设备的安装、更换和维修。

警告

只有經過受訓且具資格人員才可安裝、更換與維修此設備。

Warnung

Nur autorisiertes Personal und qualifizierte Servicetechniker dürfen dieses Gerät installieren, austauschen oder warten..

¡Advertencia!

Sólo el personal autorizado y el personal de servicio calificado deben poder instalar, reemplazar o dar servicio a este equipo.

Attention

Seul le personnel autorisé et le personnel de maintenance qualifié doivent être autorisés à installer, remplacer ou entretenir cet équipement..

אזהרה!

יש לאפשר רק צוות מורשה ואנשי שירות מוסמכים להתקין, להחליף או לטפל בציוד זה.

ينبغي السماح فقط للموظفين المعتمدين وأفراد الخدمة المؤهلين بتركيب هذا الجهاز أو استبداله أو صيانته.

경고!

승인된 직원과 자격을 갖춘 서비스 담당자만이 이 장비를 설치, 교체 또는 서비스할 수 있습니다.

Waarschuwing

Alleen geautoriseerd personeel en gekwalificeerd onderhoudspersoneel mag deze apparatuur installeren, vervangen of onderhouden..

Restricted Area

Warning! This unit is intended for installation in restricted access areas. A restricted access area can be accessed only through the use of a special tool, lock and key, or other means of security. (This warning does not apply to workstations).

アクセス制限区域

このユニットは、アクセス制限区域に設置されることを想定しています。

アクセス制限区域は、特別なツール、鍵と錠前、その他のセキュリティの手段を用いてのみ出入りが可能です。

警告

此部件应安装在限制进出的场所，限制进出的场所指只能通过使用特殊工具、锁和钥匙或其它安全手段进出的场所。

警告

此裝置僅限安裝於進出管制區域，進出管制區域係指僅能以特殊工具、鎖頭及鑰匙或其他安全方式才能進入的區域。

Warnung

Diese Einheit ist zur Installation in Bereichen mit beschränktem Zutritt vorgesehen. Der Zutritt zu derartigen Bereichen ist nur mit einem Spezialwerkzeug, Schloss und Schlüssel oder einer sonstigen Sicherheitsvorkehrung möglich.

¡Advertencia!

Esta unidad ha sido diseñada para instalación en áreas de acceso restringido. Sólo puede obtenerse acceso a una de estas áreas mediante la utilización de una herramienta especial, cerradura con llave u otro medio de seguridad.

Attention

Cet appareil doit être installé dans des zones d'accès réservés. L'accès à une zone d'accès réservé n'est possible qu'en utilisant un outil spécial, un mécanisme de verrouillage et une clé, ou tout autre moyen de sécurité.

אזור עם גישה מוגבלת

אזהרה!

יש להתקין את היחידה באזורים שיש בהם הגבלת גישה. הגישה ניתנת בעזרת 'כלי אבטחה בלבד' (מפתח, מנעול וכד.).

تخصيص هذه انحدة نترك بُها ف مناطق محظورة تم .

،ممكن اننصل إن منطقت محظورة فقط من خلال استخذاو أداة خاصت أو أ وس هُت أخري نلالأمما ققم ومفتاح

경고!

이 장치는 접근이 제한된 구역에 설치하도록 되어있습니다. 특수도구, 잠금 장치 및 키, 또는 기타 보안 수단을 통해서만 접근 제한 구역에 들어갈 수 있습니다.

Waarschuwing

Dit apparaat is bedoeld voor installatie in gebieden met een beperkte toegang. Toegang tot dergelijke gebieden kunnen alleen verkregen worden door gebruik te maken van speciaal gereedschap, slot en sleutel of andere veiligheidsmaatregelen.

Battery Handling



CAUTION: There is risk of explosion if the battery is replaced by an incorrect type. Replace the battery only with the same or equivalent type recommended by the manufacturer. Dispose of used batteries according to the manufacturer's instructions

電池の取り扱い

バッテリーを間違ったタイプに交換すると爆発の危険があります。交換する電池はメーカーが推奨する型、または同等のものを使用下さい。使用済電池は製造元の指示に従って処分して下さい。

警告

如果更换的电池类型不正确，则存在爆炸危险。请只使用同类电池或制造商推荐的功能相当的电池更换原有电池。请按制造商的说明处理废旧电池。

警告

如果更換的電池類型不正確，則有爆炸危險。請使用製造商建議之相同或功能相當的電池更換原有電池。請按照製造商的說明指示處理廢棄舊電池。

WARNUNG

Es besteht Explosionsgefahr, wenn die Batterie durch einen falschen Typ ersetzt wird. Ersetzen Sie die Batterie nur durch den gleichen oder vom Hersteller empfohlenen Batterietyp. Entsorgen Sie die benutzten Batterien nach den Anweisungen des Herstellers.

ATTENTION

Il existe un risque d'explosion si la batterie est remplacée par un type incorrect. Ne la remplacer que par une pile de type semblable ou équivalent, recommandée par le fabricant. Jeter les piles usagées conformément aux instructions du fabricant.

ADVERTENCIA

Existe riesgo de explosión si la batería se reemplaza por un tipo incorrecto. Reemplazar la batería exclusivamente con el mismo tipo o el equivalente recomendado por el fabricante. Desechar las baterías gastadas según las instrucciones del fabricante.

אזהרה!

קיימת סכנת פיצוץ אם הסוללה תוחלף בסוג שגוי. יש להחליף את הסוללה בסוג התואם מחברת יצרן מומלצת. סילוק הסוללות המשומשות יש לבצע לפי הוראות היצרן.

هناك خطر الانفجار إذا تم استبدال البطارية بنوع غير صحيح.
 اسحبذال البطارية
 فقط بنفس النوع أو ما يعادلها مما أوصت به الشركة المصنعة
 جخلص من البطاريات المسحمة وفقا لعمليات الشركة الصانعة

경고!

배터리를 잘못된 종류로 교체하면 폭발의 위험이 있습니다. 기존 배터리와 동일하거나 제조사에서 권장하는 동등한 종류의 배터리로만 교체해야 합니다. 제조사의 안내에 따라 사용된 배터리를 처리하여 주십시오.

WAARSCHUWING

Er bestaat explosiegevaar als de batterij wordt vervangen door een verkeerd type. Vervang de batterij slechts met hetzelfde of een equivalent type die door de fabrikant aanbevolen wordt. Gebruikte batterijen dienen overeenkomstig fabrieksvoorschriften afgevoerd te worden.

Redundant Power Supplies



Warning! This unit might have more than one power supply connection. All connections must be removed to de-energize the unit.

冗長電源装置

このユニットは複数の電源装置が接続されている場合があります。

ユニットの電源を切るためには、すべての接続を取り外さなければなりません。

警告

此部件连接的电源可能不止一个，必须将所有电源断开才能停止给该部件供电。

警告

此装置连接的电源可能不只一个，必须切断所有电源才能停止对该装置的供电。

Warnung

Dieses Gerät kann mehr als eine Stromzufuhr haben. Um sicherzustellen, dass der Einheit kein Strom zugeführt wird, müssen alle Verbindungen entfernt werden.

¡Advertencia!

Puede que esta unidad tenga más de una conexión para fuentes de alimentación. Para cortar por completo el suministro de energía, deben desconectarse todas las conexiones.

Attention

Cette unité peut avoir plus d'une connexion d'alimentation. Pour supprimer toute tension et tout courant électrique de l'unité, toutes les connexions d'alimentation doivent être débranchées.

אם קיים יותר מספק אחד

אזהרה!

ליחידה יש יותר מחיבור אחד של ספק. יש להסיר את כל החיבורים על מנת לרוקן את היחידה.

قد يكون لهذا الجهاز عدة اتصالات بوحدات امداد الطاقة .

يجب إزالة كافة الاتصالات لعسل الوحدة عن الكهرباء

경고!

이 장치에는 한 개 이상의 전원 공급 단자가 연결되어 있을 수 있습니다. 이 장치에 전원을 차단하기 위해서는 모든 연결 단자를 제거해야만 합니다.

Waarschuwing

Deze eenheid kan meer dan één stroomtoevoeraansluiting bevatten. Alle aansluitingen dienen verwijderd te worden om het apparaat stroomloos te maken.

Backplane Voltage



Warning! Hazardous voltage or energy is present on the backplane when the system is operating. Use caution when servicing.

バックプレーンの電圧

システムの稼働中は危険な電圧または電力が、バックプレーン上にかかっています。

修理する際には注意ください。

警告

当系统正在进行时，背板上有很危险的电压或能量，进行维修时务必小心。

警告

當系統正在進行時，背板上有危險的電壓或能量，進行維修時務必小心。

Warnung

Wenn das System in Betrieb ist, treten auf der Rückwandplatine gefährliche Spannungen oder Energien auf. Vorsicht bei der Wartung.

¡Advertencia!

Cuando el sistema está en funcionamiento, el voltaje del plano trasero es peligroso. Tenga cuidado cuando lo revise.

Attention

Lorsque le système est en fonctionnement, des tensions électriques circulent sur le fond de panier. Prendre des précautions lors de la maintenance.

מתח בפנל האחורי

אזהרה!

קיימת סכנת מתח בפנל האחורי בזמן תפעול המערכת. יש להיזהר במהלך העבודה.

هناك خطر من التيار الكهربائي أو الطاقة المتجددة على اللوحة
عندما يكون النظام يعمل كه حذرا عند خدمة هذا الجهاز

경고!

시스템이 동작 중일 때 후면판 (Backplane)에는 위험한 전압이나 에너지가 발생 합니다.
서비스 작업 시 주의하십시오.

Waarschuwing

Een gevaarlijke spanning of energie is aanwezig op de backplane wanneer het systeem in gebruik is. Voorzichtigheid is geboden tijdens het onderhoud.

Comply with Local and National Electrical Codes



Warning! Installation of the equipment must comply with local and national electrical codes.

地方および国の電気規格に準拠

機器の取り付けはその地方および国の電気規格に準拠する必要があります。

警告

设备安装必须符合本地与本国电气法规。

警告

設備安裝必須符合本地與本國電氣法規。

Warnung

Die Installation der Geräte muss den Sicherheitsstandards entsprechen.

¡Advertencia!

La instalación del equipo debe cumplir con las normas de electricidad locales y nacionales.

Attention

L'équipement doit être installé conformément aux normes électriques nationales et locales.

תיאום חוקי החשמל הארצי
אזהרה!
התקנת הציוד חייבת להיות תואמת לחוקי החשמל המקומיים והארציים.

تركيب المعدات الكهربائية يجب أن يمتثل للقوايه المحلية والبطية المتعلقة
بالكهرباء

경고!

현 지역 및 국가의 전기 규정에 따라 장비를 설치해야 합니다.

Waarschuwing

Bij installatie van de apparatuur moet worden voldaan aan de lokale en nationale elektriciteitsvoorschriften.

Product Disposal



Warning! Ultimate disposal of this product should be handled according to all national laws and regulations.

製品の廃棄

この製品を廃棄処分する場合、国の関係する全ての法律・条例に従い処理する必要があります。

警告

本产品的废弃处理应根据所有国家的法律和规章进行。

警告

本產品的廢棄處理應根據所有國家的法律和規章進行。

Warnung

Die Entsorgung dieses Produkts sollte gemäß allen Bestimmungen und Gesetzen des Landes erfolgen.

¡Advertencia!

Al deshacerse por completo de este producto debe seguir todas las leyes y reglamentos nacionales.

Attention

La mise au rebut ou le recyclage de ce produit sont généralement soumis à des lois et/ou directives de respect de l'environnement. Renseignez-vous auprès de l'organisme compétent.

סילוק המוצר

אזהרה!

סילוק סופי של מוצר זה חייב להיות בהתאם להנחיות וחוקי המדינה.

التخلص النهائي من هذا المنتج ينبغي التعامل معه وفقا لجميع القوانين واللوائح الوطنية عند

경고!

이 제품은 해당 국가의 관련 법규 및 규정에 따라 폐기되어야 합니다.

Waarschuwing

De uiteindelijke verwijdering van dit product dient te geschieden in overeenstemming met alle nationale wetten en reglementen.

Fan Warning



Warning! Hazardous moving parts. Keep away from moving fan blades. The fans might still be turning when you remove the fan assembly from the chassis. Keep fingers, screwdrivers, and other objects away from the openings in the fan assembly's housing.

ファンの警告

警告!回転部品に注意。運転中は回転部(羽根)に触れないでください。シャーシから冷却ファン装置を取り外した際、ファンがまだ回転している可能性があります。ファンの開口部に、指、ドライバー、およびその他のものを近づけないで下さい。

警告!

警告! 危險的可移動性零件。請務必與轉動的风扇叶片保持距離。當您從機架移除風扇裝置，風扇可能仍在轉動。小心不要將手指、螺絲起子和其他物品太靠近風扇

警告

危險的可移動性零件。請務必與轉動的风扇叶片保持距離。當您從機架移除風扇裝置，風扇可能仍在轉動。小心不要將手指、螺絲起子和其他物品太靠近風扇。

Warnung

Gefährlich Bewegende Teile. Von den bewegenden Lüfterblätter fern halten. Die Lüfter drehen sich u. U. noch, wenn die Lüfterbaugruppe aus dem Chassis genommen wird. Halten Sie Finger, Schraubendreher und andere Gegenstände von den Öffnungen des Lüftergehäuses entfernt.

¡Advertencia!

Riesgo de piezas móviles. Mantener alejado de las aspas del ventilador. Los ventiladores podran dar vuelta cuando usted quite el montaje del ventilador del chasis. Mantenga los dedos, los destornilladores y todos los objetos lejos de las aberturas del ventilador

Attention

Pieces mobiles dangereuses. Se tenir a l'écart des lames du ventilateur Il est possible que les ventilateurs soient toujours en rotation lorsque vous retirerez le bloc ventilateur du châssis. Prenez garde à ce que doigts, tournevis et autres objets soient éloignés du logement du bloc ventilateur.

אזהרה!

חלקים נעים מסוכנים. התרחק מלהבי המאוורר בפעולה כאשר מסירים את חלקי המאוורר מהמארז, יתכן והמאווררים עדיין עובדים. יש להרחיק למרחק בטוח את האצבעות וכלי עבודה שונים מהפתחים בתוך המאוורר

تحذير! أجزاء متحركة خطيرة. ابتعد عن شفرات المروحة المتحركة. من الممكن أن المراوح لا تزال تدور عند إزالة كتلة المروحة من الهيكل يجب إبقاء الأصابع ومفكات البراغي وغيرها من الأشياء بعيدا عن الفتحات في كتلة المروحة

경고!

움직이는 위험한 부품. 회전하는 송풍 날개에 접근하지 마세요. 새시로부터 팬 조립품을 제거할 때 팬은 여전히 회전하고 있을 수 있습니다. 팬 조립품 외관의 열려있는 부분들로부터 손가락 및 스크류드라이버, 다른 물체들이 가까이 하지 않도록 배치해 주십시오.

Waarschuwing

Gevaarlijk bewegende onderdelen. Houd voldoende afstand tot de bewegende ventilatorbladen. Het is mogelijk dat de ventilator nog draait tijdens het verwijderen van het ventilatorsamenstel uit het chassis. Houd uw vingers, schroevendraaiers en eventuele andere voorwerpen uit de buurt van de openingen in de ventilatorbehuizing.

Power Cable and AC Adapter



Warning! When installing the product, use the provided or designated connection cables, power cables and AC adaptors. Using any other cables and adaptors could cause a malfunction or a fire. Electrical Appliance and Material Safety Law prohibits the use of UL or CSA -certified cables (that have UL/CSA shown on the cord) for any other electrical devices than products designated by Supermicro only.

電源コードとACアダプター

製品を設置する場合、提供または指定および購入された接続ケーブル、電源コードとACアダプターを該当する地域の条例や安全基準に適合するコードサイズやプラグと共に使用下さい。他のケーブルやアダプタを使用すると故障や火災の原因になることがあります。

電気用品安全法は、ULまたはCSA認定のケーブル(UL/CSAマークがコードに表記)を Supermicro が指定する製品以外に使用することを禁止しています。

警告

安装此产品时,请使用本身提供的或指定的或采购的连接线,电源线和电源适配器。包含遵照当地法规和安全要求的合规的电源线尺寸和插头。使用其它线材或适配器可能会引起故障或火灾。除了Supermicro所指定的产品,电气用品和材料安全法律规定禁止使用未经UL或CSA认证的线材。(线材上会显示UL/CSA符号)。

警告

安裝此產品時,請使用本身提供的或指定的或採購的連接線,電源線和電源適配器。包含遵照當地法規和安全要求的合規的電源線尺寸和插頭。使用其它線材或適配器可能會引起故障或火災。除了Supermicro所指定的產品,電氣用品和材料安全法律規定禁止使用未經UL或CSA認證的線材。(線材上會顯示UL/CSA符號)。

Warnung

Nutzen Sie beim Installieren des Produkts ausschließlich die von uns zur Verfügung gestellten Verbindungskabeln, Stromkabeln und/oder Adapter, die Ihre örtlichen Sicherheitsstandards einhalten. Der Gebrauch von anderen Kabeln und Adapter können Fehlfunktionen oder Feuer verursachen. Die Richtlinien untersagen das Nutzen von UL oder CAS zertifizierten Kabeln (mit UL/CSA gekennzeichnet), an Geräten oder Produkten die nicht mit Supermicro gekennzeichnet sind.

¡Advertencia!

Cuando instale el producto, utilice la conexión provista o designada o procure cables, Cables de alimentación y adaptadores de CA que cumplan con los códigos locales y los requisitos de seguridad, incluyendo el tamaño adecuado del cable y el enchufe. El uso de otros cables y adaptadores podría causar un mal funcionamiento o un incendio. La Ley de Seguridad de Aparatos Eléctricos y de Materiales prohíbe El uso de cables certificados por UL o CSA (que tienen el certificado UL / CSA en el código) para cualquier otros dispositivos eléctricos que los productos designados únicamente por Supermicro.

Attention

Lors de l'installation du produit, utilisez les cables de connection fournis ou désigné ou achetez des cables, cables de puissance et adaptateurs respectant les normes locales et les conditions de securite y compris les tailles de cables et les prises electriques appropries. L'utilisation d'autres cables et adaptateurs peut provoquer un dysfonctionnement ou un incendie. Appareils électroménagers et la Loi sur la Sécurité Matériel interdit l'utilisation de câbles certifiés- UL ou CSA (qui ont UL ou CSA indiqué sur le code) pour tous les autres appareils électriques sauf les produits désignés par Supermicro seulement.

AC ימאתמו מיימשח מילבכ

!הרהזא

ךרוצל ומאתוה וא ושכרנ רשא AC מיימאתמו מיקפס, מילבכב שמתשהל שי, רצומה תא מיניקתמ רשאכ לכב שומיש . עקתהו לבכה לש הנוכח הדימ ללוכ, תוימוקמה תוחיטבה תושירדל ומאתוה רשאו, הנקתהה למשחה ירישכמב שומישה יקוחל מאתהב. ילמשח רצק וא הלקתל מורגל לולע, רחא גוסמ מאתמ וא לבכ לש דוק מהילע עיפומ רשאכ) UL-ב או CSA-ב (ב-מייכמוסומה מילבכב שמתשהל רוסיא מייק, תוחיטבה יקוחו דבלב Supermicro י"ע מאתוה רשא רצומב קר אלא, רחא ילמשח רצומ לכ רובע UL/CSA)

תאלבאלא אארשב מץ וא עדדחמלא וא ערפוטמלא תאליטוטלא מאדחטסאב מץ, גתנמלא בייקרת דנע לכלז יפ אמב עילחמלא עמאלסלא תאבלטתמו נינאווקב מאזתלאלא עמ דדרתמלא ראיטלא תאלוחמו עיזאברמלא קיירח וא לטע יפ בבסטטי דץ ירזא תאלוחמו תאלבאלא יא מאדחטסא. מילסלא סבאלאו ולסומלא מץ ח. CSA וא UL לבק נמ ענדמתמלא תאלבאלא מאדחטסא תאדעמלא עיזאברמלא עזגאלל עמאלסלא נונאק רזחי Supermicro לבק נמ עדדחמלא עינעמלא תאגתנמלא ריזג ירזא תאדעמ יא עמ (UL/CSA) עמאלע למחתיטלאו

전원 케이블 및 AC 어댑터

경고! 제품을 설치할 때 현지 코드 및 적절한 굵기의 코드와 플러그를 포함한 안전 요구 사항을 준수하여 제공되거나 지정된 연결 혹은 구매 케이블, 전원 케이블 및 AC 어댑터를 사용하십시오.

다른 케이블이나 어댑터를 사용하면 오작동이나 화재가 발생할 수 있습니다. 전기 용품 안전법은 UL 또는 CSA 인증 케이블 (코드에 UL / CSA가 표시된 케이블)을 Supermicro 가 지정한 제품 이외의 전기 장치에 사용하는 것을 금지합니다.

Stroomkabel en AC-Adapter

Waarschuwing! Bij het aansluiten van het Product uitsluitend gebruik maken van de geleverde Kabels of een andere geschikte aan te schaffen Aansluitmethode, deze moet altijd voldoen aan de lokale voorschriften en veiligheidsnormen, inclusief de juiste kabeldikte en stekker. Het gebruik van niet geschikte Kabels en/of Adapters kan een storing of brand veroorzaken. Wetgeving voor Elektrische apparatuur en Materiaalveiligheid verbied het gebruik van UL of CSA -gecertificeerde Kabels (met UL/CSA in de code) voor elke andere toepassing dan de door Supermicro hiervoor beoogde Producten.

Appendix B

System Specifications

Processors

Single AMD EPYCTM 9004/9005 (Motherboard revision 2.0 or above is required) Series processors in Socket SP5

Chipset

System on Chip

BIOS

256 Mb SPI AMI BIOS® SM Flash UEFI BIOS

ACPI 6.4, SMBIOS 3.5.0, Plug-and-Play (PnP), RTC (Real Time Clock) wakeup, Riser Card Auto-Detection Support

Memory

12 DIMM slots with 1DPC that support

- 3 TB of ECC DDR5/3DS RDIMM at 4800 MT/s (AMD EPYC™ 9004 Series Processors)
- 3 TB of ECC DDR5/3DS RDIMM at 6000 MT/s (Requires AMD EPYC™ 9005 Series Processors and motherboard revision 2.00 or later)
- 3 TB of ECC DDR5/3DS RDIMM at 6400 MT/s (Requires AMD EPYC™ 9005 Series Processors and motherboard revision 2.01 or later)

See [Section 3.4](#) for details

Storage Drives

12 3.5"/2.5" hot-swap hybrid SATA/NVMe*/SAS* drive bays (require additional parts)

Two Gen 3 M.2 NVMe PCIe 3.0 x2 SSDs for boot drive

PCI Expansion Slots

Two PCIe 5.0 x16 FHFL (with 12 NVMe, only 1 FHFL available)

Two PCIe 5.0 x16 FHHL

Two PCIe 5.0 x8 FHFL (optional)*

*PCIe Slots 2 and 4 are not available with NVMe drive option

Input/Output

Network: One or two AIOM modules (OCP 3.0 NIC)

BMC: Dedicated IPMI LAN port

USB: Two rear USB 3.0 ports

Video: One VGA port

COM: One serial port

Motherboard

H13SSW: 12.29" (W) x13.4" (L) (312.16 x 340.36 mm)

Chassis

CSE-LA26TS-R1K23AWP1: 2U Rackmount, (WxHxD) 17.2 x 3.5 x 25.5 in. (43.7 x 8.9 x 64.8 cm)

System Cooling

Three 4-cm counter-rotating fans, one CPU heatsinks, air shroud to direct air flow

Power Supply

PWS-1K23A-1R, 1000 W/1200 W redundant modules, 80Plus Platinum level*

AC Input

1000 W: 100-127 Vac / 15 A-12 A / 50-60 Hz

1200 W: 200-240 Vac / 8.5 A-7 A / 50-60 Hz

+12 V

Max: 83 A / Min: 0 A (100 Vac-127 Vac)

Max: 100 A / Min: 0 A (200 Vac-240 Vac)

5 V SB

Max: 4 A / Min: 0 A

*Full redundancy based on configuration and application load.

Operating Environment

Operating Temperature: 10° to 35° C (50° to 95° F)*

Non-operating Temperature: -40° to 60° C (-40° to 140° F)

Operating Relative Humidity: 8% to 90% (non-condensing)

Non-operating Relative Humidity: 5% to 95% (non-condensing)

*Note: Operating Temperature based on configurations

Regulatory Compliance

FCC, ICES, CE, VCCI, RCM, UKCA, NRTL, CB

Applied Directives, Standards

EMC/EMI: 2014/30/EU (EMC Directive) CLASS A

Electromagnetic Compatibility Regulations 2016

FCC Part 15 Subpart B

ICES-003

VCCI-CISPR 32

AS/NZS CISPR 32

BS/EN55032

BS/EN55035

CISPR 32

CISPR 35

BS/EN 61000-3-2

BS/EN 61000-3-3

BS/EN 61000-4-2

BS/EN 61000-4-3

BS/EN 61000-4-4

BS/EN 61000-4-5

BS/EN 61000-4-6

BS/EN 61000-4-8

BS/EN 61000-4-11

Environment:

2011/65/EU (RoHS Directive)

EC 1907/2006 (REACH)

2012/19/EU (WEEE Directive)

California Proposition 65

Product Safety: 2014/35/EU (LVD Directive)

UL/CSA 62368-1 (USA and Canada)

Electrical Equipment (Safety) Regulations 2016

IEC/BS/EN 62368-1

Perchlorate Warning

California Best Management Practices Regulations for Perchlorate Materials: This Perchlorate warning applies only to products containing CR (Manganese Dioxide) Lithium coin cells. "Perchlorate Material-special handling may apply. See www.dtsc.ca.gov/hazardouswaste/perchlorate"

この装置は、クラスA機器です。この装置を住宅環境で使用すると電波妨害を引き起こすことがあります。この場合には使用者が適切な対策を講ずるよう要求されることがあります。

VCCI - A